



# JS-TERRA Series 350/450/550 Operation Manual

Thank you for purchasing the JS TERRA Series.  
Read these instructions thoroughly for proper use of this machine.

Make sure to read "Safety Notes" before you use machine.

This information protects you from possible dangers during use.

Apollo Seiko Ltd.

Rev. 201403

## Safety Notes

This manual includes the important information to use machine safely. This also includes useful information to prevent avoiding injury or damaging property.

Please read this manual carefully prior to connecting or operating the JS-TERRA

Keep this manual nearby the machine all the time.

### Supply only specified voltage

Do not connect to a power supply greater than the specified voltage. If not, electrical shock and /or damage to the unit may occur.

Make sure that the electrical outlet is properly grounded. If the outlet is not properly grounded, electrical shock and/or damage to the unit may occur.

### Working ambient temperature and relative humidity

This machine has been designed to use between 0~40 degree, 10%~90%. Do not use this machine under the condition exceeding here-in.

### Handle with care

This machine is designed to use solder feeder and heating iron for soldering.

If you touch a heated soldering iron, it will burn yourself. So, make sure the iron is cool down before you are touching it for replacing the iron cartridge.

Please handle this machine with care. If you drop or make a big impact/ vibration, it may cause malfunction.

### If you do not use the machine for a long time

Please turn off the power, remove the power cable and keep it in dry and cool place.

### If you note malfunction on machine

If the machine becomes a malfunction, turn off the power immediately and contact a dealer you purchased machine from.

### Immunity from responsibility

We do take NO responsibility on a damage caused by misuse, mistake, accident, uses in abnormal condition or natural disaster such as an earthquake, a fire etc.

We do take NO responsibility on contingency loss (Business loss, Business stop) caused by machine stop.

We do take NO responsibility on a loss caused by the operation not mentioning on this manual.

We do take NO responsibility on a loss caused by a wrong connection with other equipment.

If for any reason the internal circuitry is tampered with altered or repaired without written consent of Apollo Seiko, the warranty is null and void. The customer is allowed to make necessary tooling adjustment, replace solder iron tips and make any necessary adjustments to the temperature controller.

## Index

---

Safety Notes .....	2
Index .....	3
1. Dimensions .....	4
2. Summary of JS-TERRA .....	8
3. Description .....	8
4. WK parameter setting .....	10
5. How to change TERRA system parameter .....	15
6. Operation .....	17
7. Input and output wiring diagram .....	19
8. Timing chart .....	22
9. ZSB feeder adjustment and alignment (Option) .....	31
10. Maintenance .....	33
11. Trouble shooting .....	34
12. Handling and Care of Iron Tip .....	36
13. How to change iron tip .....	38

# 1. Dimensions

## JS250-TERRA

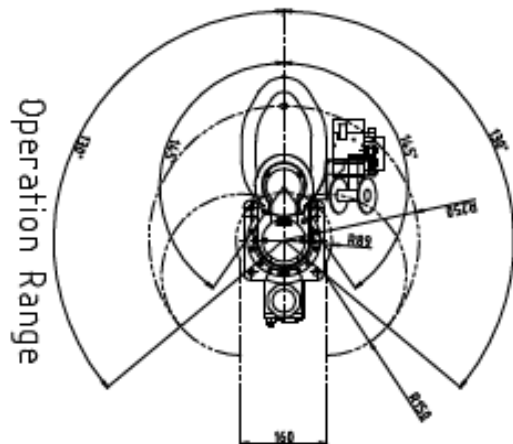
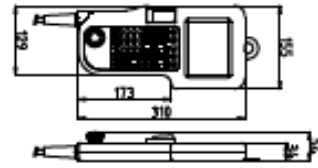
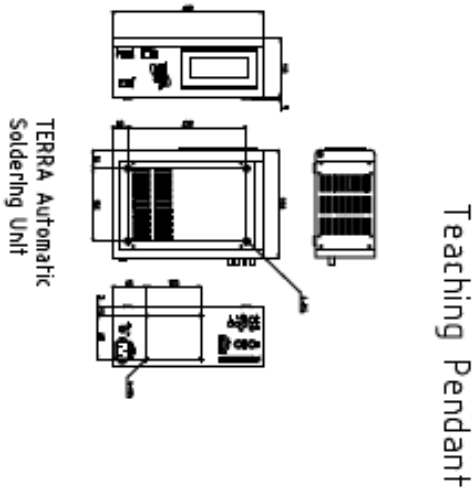

## JS-250 TERRA + RSP

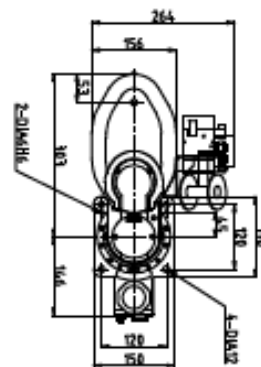
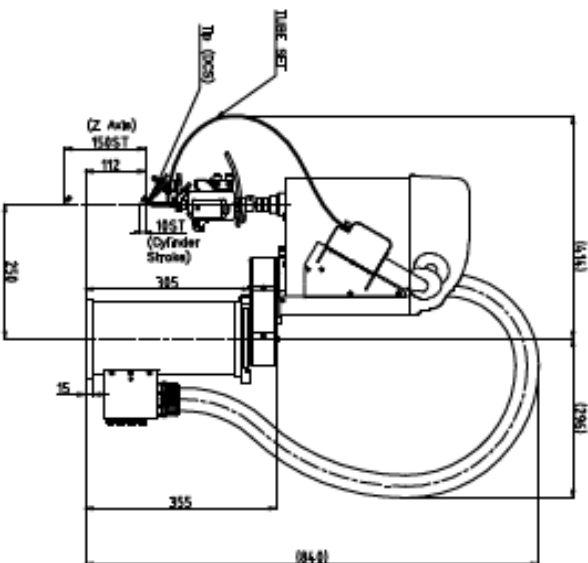
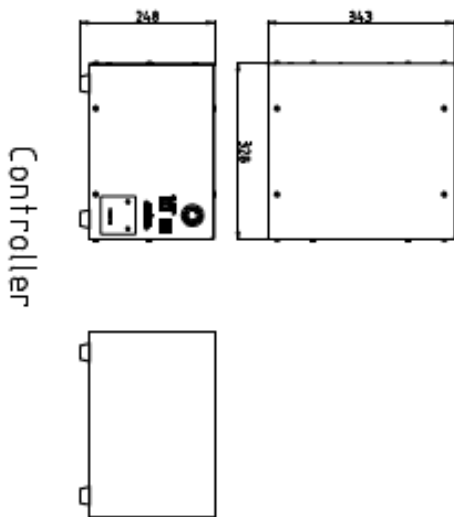



JS450-TERRA

TERRA Automatic  
Soldering Unit

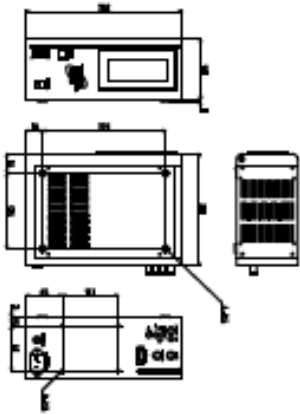

Teaching Pendant

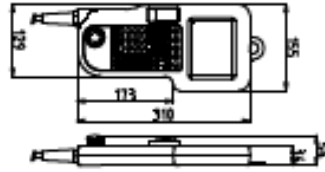

Operation Range

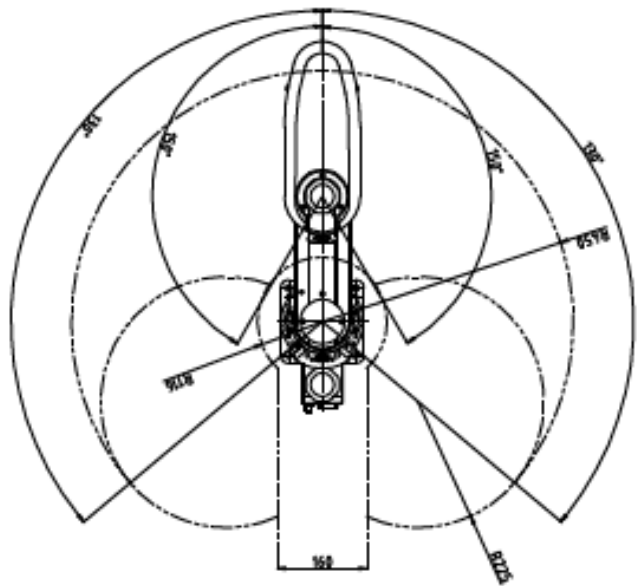

Controller

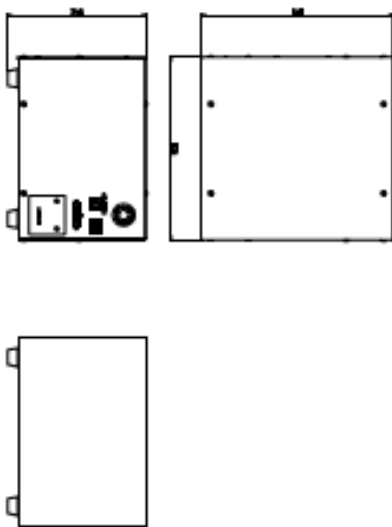

JS-450 TERRA + RSP

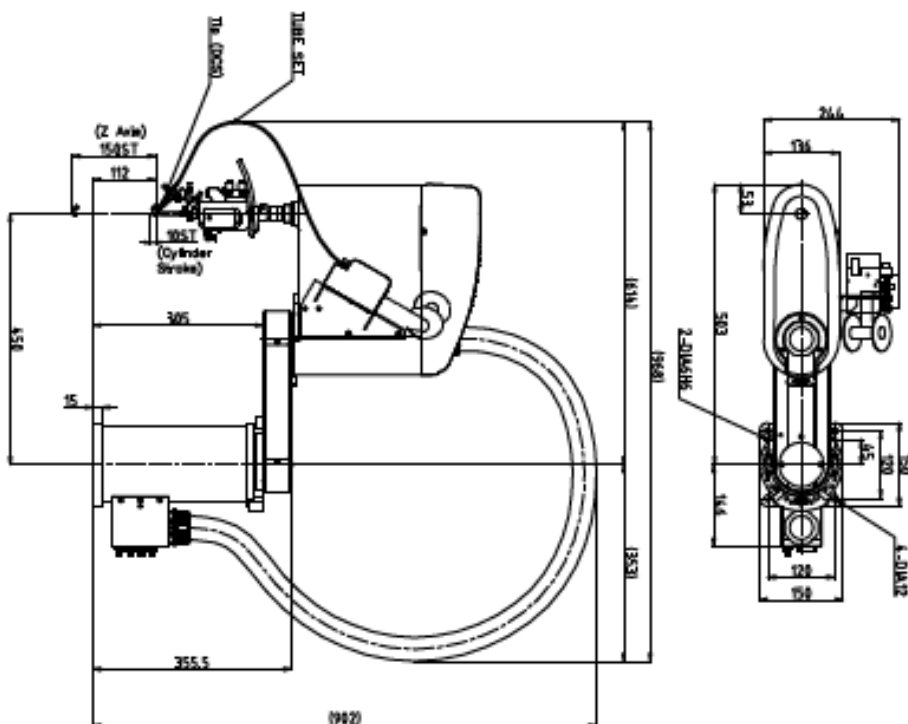



## 2. Summary of JS-TERRA

The RSP/RSL iron unit and ZSB feeder are built-in with JS550-TERRA. The DCS iron will assure very stable soldering temperature and the ZSB will guarantee zero solder ball soldering result.

## 3. Description

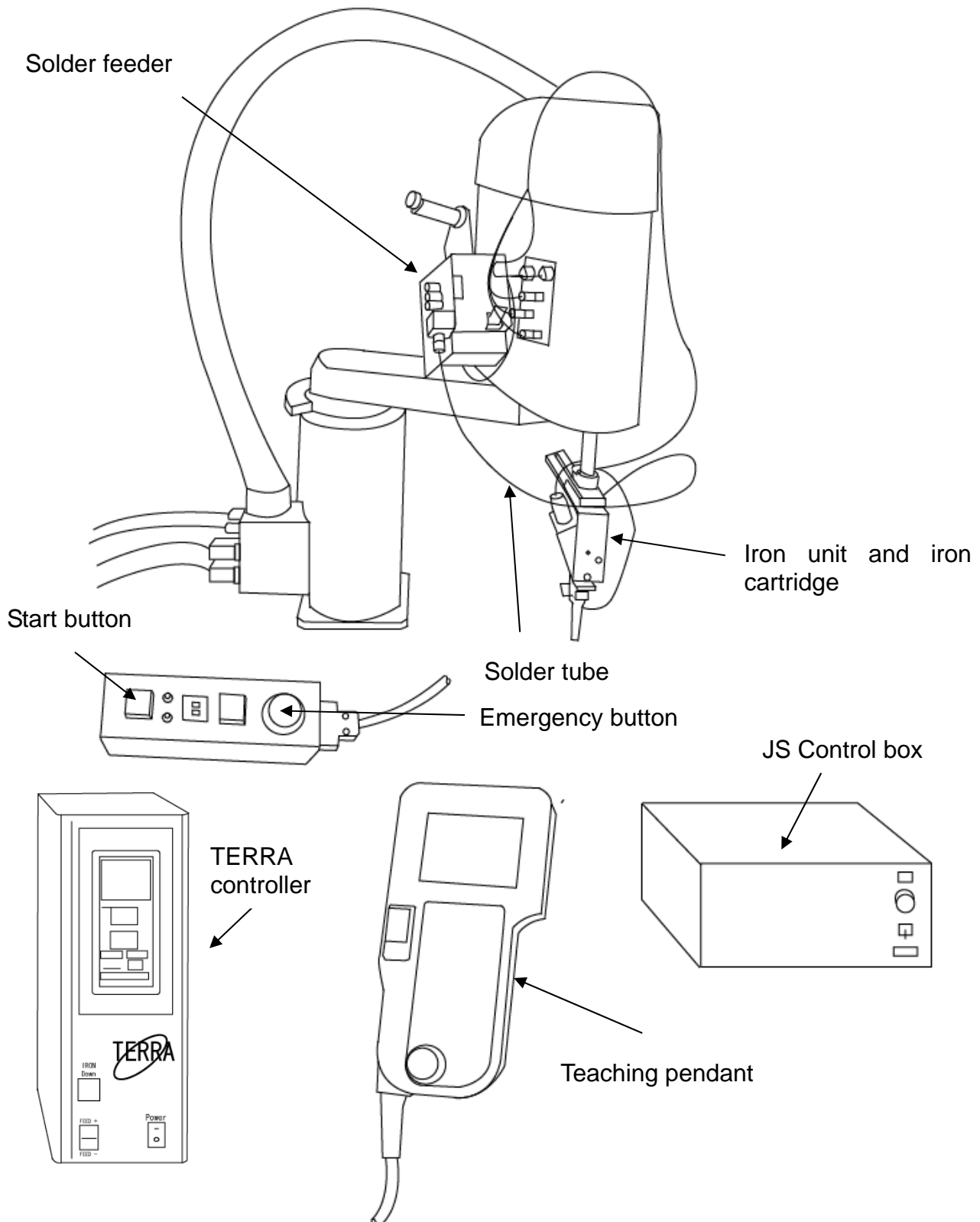



A) TERRA controller front

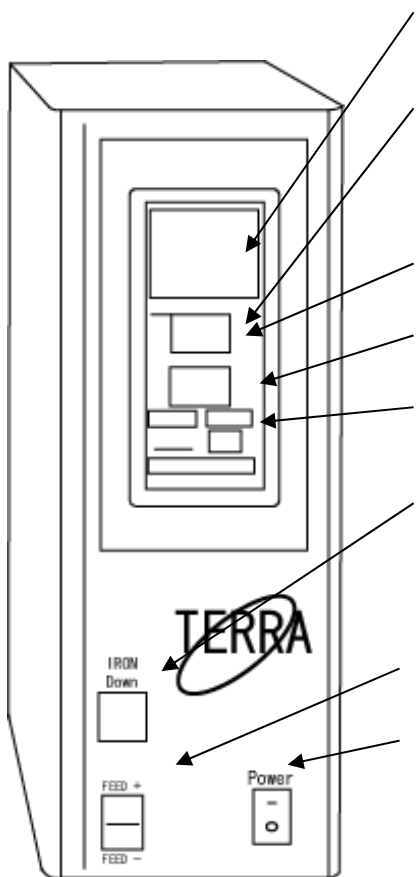

- ① Temperature trend graph display  
The temperature trend is displayed on the screen in real-time.
- ② Temperature display  
The iron temperature is displayed. To change the setting temperature, press the Set Temp button and enter desired temperature using Ten key, then press ↵ key.
- ③ WK number display  
Current operating WK number is displayed.
- ④ Heat On /Off  
The iron heater is turned on/off to press this button.
- ⑤ System Parameter  
Press this button to change the system parameter.
- ⑥ Iron down button  
While you press this button, the iron stays at soldering position. So, when you teach soldering position, check the position using this button.
- ⑦ Solder feed forward button  
Solder wire is forwarded or reversed while this button is pressed.
- ⑧ Power switch  
Turn it on to start TERRA controller.

B) TERRA back

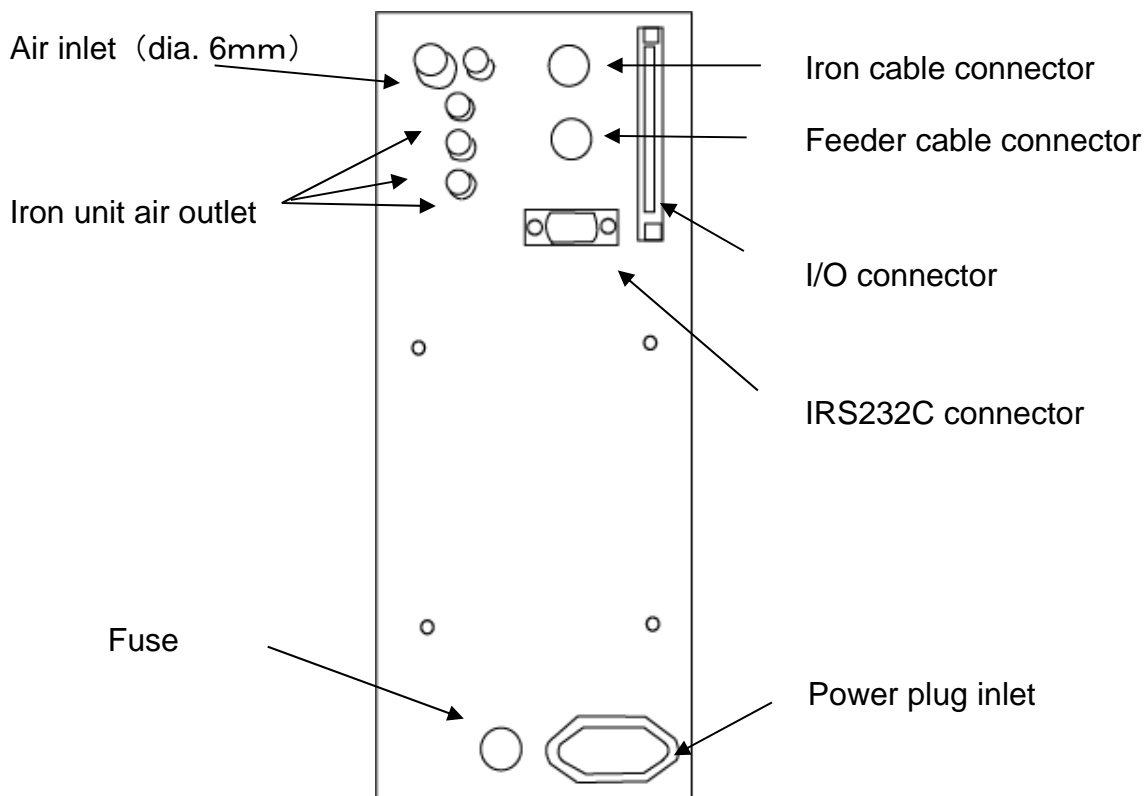

## 4. WK parameter setting

4-1. Turn ON the robot/TERRA and do the entering of the soldering conditions (WK parameter) and the positions.

Refer to the Operation Manual of robot and do the teaching of soldering position and cleaning position.

Soldering condition number for point soldering (Third soldering <sup>⑫</sup> - <sup>⑰</sup> cannot be set.)	101-199
Soldering condition number for line soldering	201-299
Soldering condition number for special point soldering	301-399

- 1) Turn on the power.
- 2) The screen changes to green color after while and shows the operation screen. If not check the air supply and the iron cartridge.

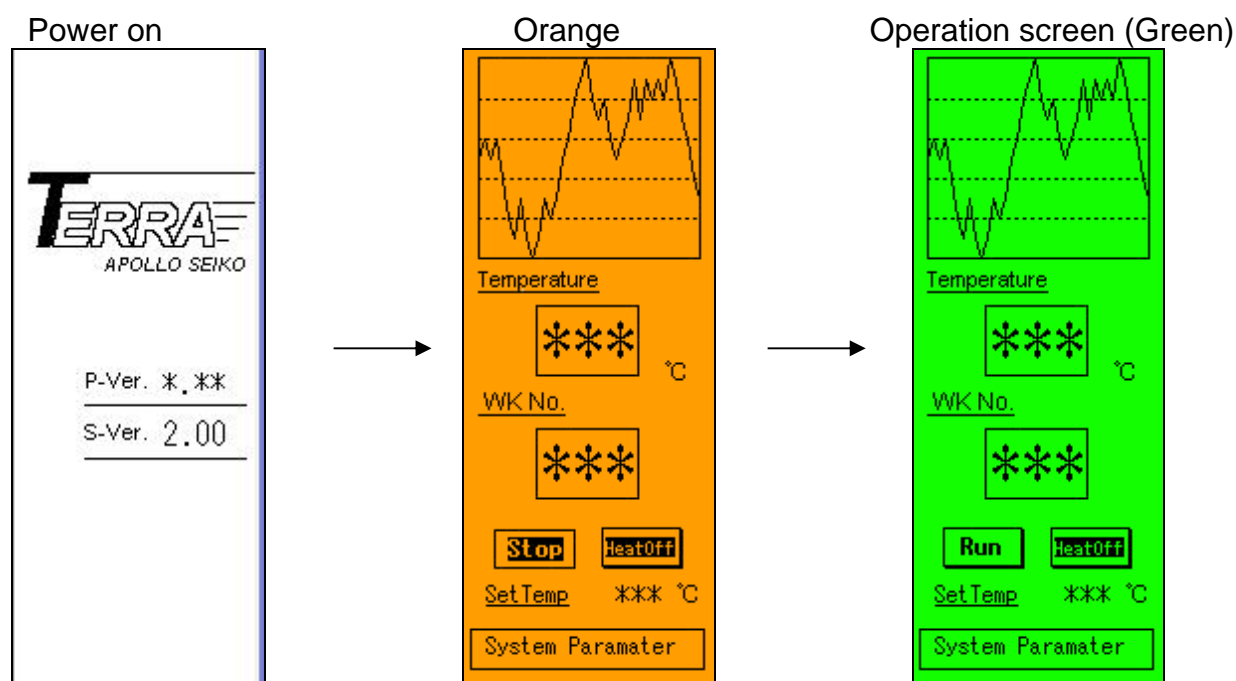

4-2. Useful function with the teaching pendant.

Teaching screen :

Key	Action
0	The solder iron will go down while this key is pressed.
1	The solder iron will go down if this key is pressed once. To raise, press "0" key again.
3	The solder wire feed forward while this key is pressed.
4	The machine blow an air while this key is pressed.
6	The solder wire feed reverse while this key is pressed.

Setting display screen :

Key	Action
Go	The machine move to the displayed position.
F4	The machine move to the displayed position and do the soldering with the entered condition.

4.3

- 1) Press WK Cond.Set key. The WK selection screen is displayed.
- 2) Enter the WK number. Ex.) 101  
Then condition screen is displayed.
- 3) Input value is displayed on the parameter screen.
- 4) If need change, press the box of input value. Press the changing number.
- 5) Press  $\leftarrow$  key.
- 6) Press ENT.
- 7) Press WRITE, after the "Writing" display finishes, entering is completed.

Setting screen Example

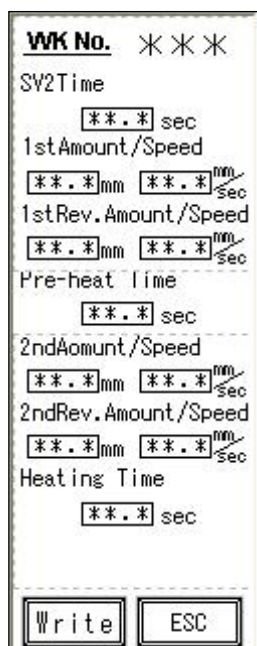

Point soldering  
(WK101-199)

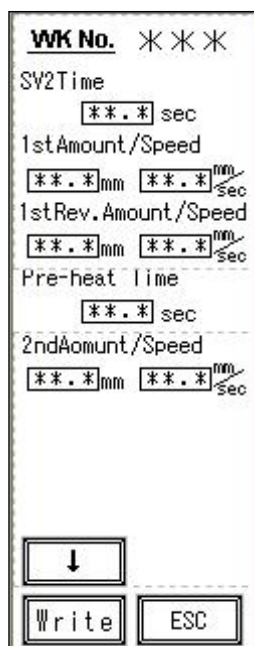

Slide soldering  
(WK201-299)

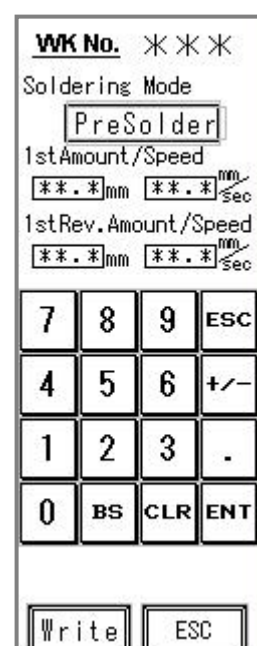
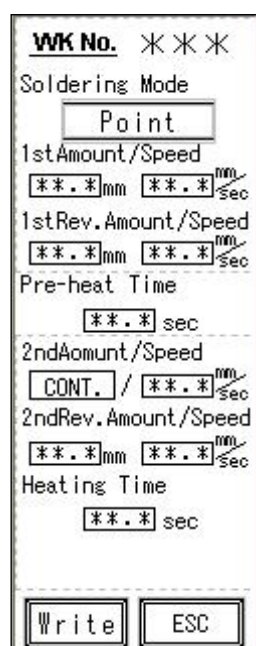
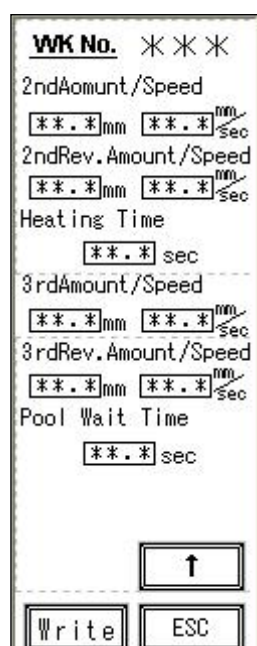
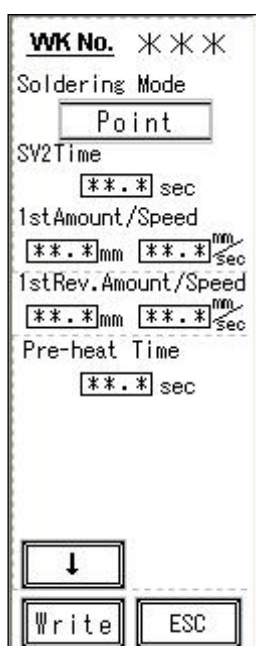
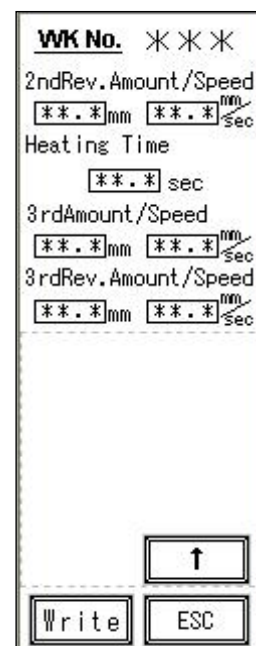

Special soldering  
(WK301-399)

## 4.4 Soldering condition settings are as follows.

## Point soldering (WK101-199)

WK101-199	Command	Adjustable range	
Point	SV2 Time		0-99.9sec
	1 <sup>st</sup> Amount / Speed	0-99.9mm	SP0.1-99.9
	1 <sup>st</sup> Rev. Amount / Speed	0-99.9mm	SP0.1-99.9
	Pre-Heat Time		0-99.9sec
	2 <sup>nd</sup> Amount / Speed	0-99.9mm	SP0.1-99.9
	2 <sup>nd</sup> Rev Amount / Speed	0-99.9mm	SP0.1-99.9
	Heating Time		0-99.9sec

## Line soldering (WK201-299)

WK201-299	Command	Adjustable range	
Line	SV2 Time		0-99.9sec
	1 <sup>st</sup> Amount / Speed	0-99.9mm	SP0.1-99.9
	1 <sup>st</sup> Rev. Amount / Speed	0-99.9mm	SP0.1-99.9
	Pre-Heat Time		0-99.9sec
	2 <sup>nd</sup> Amount / Speed	0-99.9mm	SP0.1-99.9
	2 <sup>nd</sup> Rev Amount / Speed	0-99.9mm	SP0.1-99.9
	Heating Time		0-99.9sec
	3 <sup>rd</sup> Amount / Speed	0-99.9mm	SP0.1-99.9
	3 <sup>rd</sup> Rev Amount / Speed	0-99.9mm	SP0.1-99.9

## Special soldering : Point soldering (WK 301-399)

WK301-399	Command	Adjustable range	
Point	SV2 Time		0-99.9sec
	1 <sup>st</sup> Amount / Speed	0-99.9mm	SP0.1-50.0
	1 <sup>st</sup> Rev.Amount / Speed	0-99.9mm	SP0.1-50.0
	Pre-Heat Time		0-99.9sec
	2 <sup>nd</sup> Amount / Speed	0-99.9mm	SP0.1-50.0
	2 <sup>nd</sup> Rev Amount / Speed	0-99.9mm	SP0.1-50.0
	Heating Time		0-99.9sec
	3 <sup>rd</sup> Amount / Speed	0-99.9mm	SP0.1-50.0
	3 <sup>rd</sup> Rev Amount / Speed	0-99.9mm	SP0.1-50.0

## Special soldering : Line soldering (WK 301-399)

WK301-399	Command	Adjustable range	
Line	SV2 Time		0-99.9sec
	1 <sup>st</sup> Amount / Speed	0-99.9mm	SP0.1-50.0
	1 <sup>st</sup> Rev.Amount / Speed	0-99.9mm	SP0.1-50.0
	Pre-Heat Time		0-99.9sec
	2 <sup>nd</sup> Amount / Speed	0-99.9mm	SP0.1-50.0
	2 <sup>nd</sup> Rev Amount / Speed	0-99.9mm	SP0.1-50.0
	Heating Time		0-99.9sec
	3 <sup>rd</sup> Amount / Speed	0-99.9mm	SP0.1-50.0
	3 <sup>rd</sup> Rev Amount / Speed	0-99.9mm	SP0.1-50.0
	Pool Wait Time		0-99.9sec

## Special soldering : Point soldering (No up) (WK 301-399)

WK301-399	Command	Adjustable range	
Point NoUp	SV2 Time		0-99.9sec
	1 <sup>st</sup> Amount / Speed	0-99.9mm	SP0.1-50.0
	1 <sup>st</sup> Rev.Amount / Speed	0-99.9mm	SP0.1-50.0
	Pre-Heat Time		0-99.9sec
	2 <sup>nd</sup> Amount / Speed		SP0.1-50.0
	2 <sup>nd</sup> Rev Amount / Speed	0-99.9mm	SP0.1-50.0
	Heating Time		0-99.9sec
	3 <sup>rd</sup> Amount / Speed	0-99.9mm	SP0.1-50.0
	3 <sup>rd</sup> Rev Amount / Speed	0-99.9mm	SP0.1-50.0

## Special soldering : Easy Line soldering (WK 301-399)

WK301-399	Command	Adjustable range	
Easy Line	SV2 Time		0-99.9sec
	1 <sup>st</sup> Amount / Speed	0-99.9mm	SP0.1-50.0
	1 <sup>st</sup> Rev.Amount / Speed	0-99.9mm	SP0.1-50.0
	Pre-Heat Time		0-99.9sec
	2 <sup>nd</sup> Amount / Speed		SP0.1-50.0
	2 <sup>nd</sup> Rev Amount / Speed	0-99.9mm	SP0.1-50.0
	Heating Time		0-99.9sec

## Special soldering : Pre soldering (WK 301-399)

WK301-399	Command	Adjustable range	
Pre Solder	1 <sup>st</sup> Amount / Speed	0-99.9mm	SP0.1-50.0
	1 <sup>st</sup> Rev.Amount / Speed	0-99.9mm	SP0.1-50.0

## Cleaning

WK000	Command	Adjustable range	
	Iron Up / Down	On / Off	
	Air Blow		0-99.9sec
	Wait Time		0-99.9sec



## 4.5 TERRA soldering WK commands :

① **SV2 time** (sec)

Rising time to the second setting temperature

Using for setting high temperature for the high heat-sink pattern.

② **1<sup>st</sup> Amount**, The first soldering feed amount (Pre-soldering) (mm)

Pre-soldering for tip or pattern.

Transfer the heat of the tip to the pattern.

③ **1<sup>st</sup> Speed**, The first solder feed speed (mm/sec)

Set the feed speed of the first soldering.

④ **1<sup>st</sup> Rev. Amount**, The first soldering return amount (mm)

Set the soldering return amount.

When the supply of solder wire is finished the solder wire returns because of prevention of soldering wire' waste.

- ⑤ **1<sup>st</sup> Rev. Amount**, The first reverse speed (mm/sec)  
Set the first reverse soldering speed.
- ⑥ **Pre-heat time**  
Pre-heat time is the time from the iron tip contact with the work to the start for the supply of the second soldering.
- ⑦ **2<sup>nd</sup> Amount**, Second solder feed amount (mm)  
Set the solder feed amount for the pattern.
- ⑧ **2<sup>nd</sup> Speed**, Second solder feed speed (mm/sec)  
Set the second solder speed.
- ⑨ **2<sup>nd</sup> Rev. Amount**, Second reverse amount (mm)  
Set the solder reverse amount for prevention of solder wire's waste.
- ⑩ **2<sup>nd</sup> Rev. Speed**, Second reverse speed (mm/sec)  
Set the second reverse speed.
- ⑪ **Heating time** (sec)  
Heating time is the time from the supply of the second soldering is finished to the iron tip leaves works.
- ⑫ **3<sup>rd</sup> Amount**, Third solder feed amount (mm)  
The third soldering is added if the additional solder need or prevent icicle.
- ⑬ **3<sup>rd</sup> Speed**, Third solder feed speed (mm/sec)  
Set the third solder feed speed.
- ⑭ **Rev. Amount**, Third reverse amount (mm)  
Set the third solder reverse amount.
- ⑮ **Rev. Speed**, Third reverse speed (mm/sec)  
Set the third reverse speed.
- ⑯ **Pool wait time**  
Solder pool time for slide soldering. The slide soldering starts delay time for solder pooling.

## 5. How to change TERRA system parameter

- 1) Press the Parameter key on the operation screen. The System Parameter selecting screen appears.
  - 2) Press System Parameter key to change. Eg. Alarm Hi
  - 3) The setting value appears in the next parameter setting screen.
  - 4) To change the values, press the setting value box. Then, ten key appears.
  - 5) Enter desired value and press  $\leftarrow$  key;
  - 6) Press ESC key.
  - 7) Press WRITE key. The message "Writing" appears and the entering value is memorized.
- Note : If the TYPE is changed, turn off the TERRA power and turn on again.

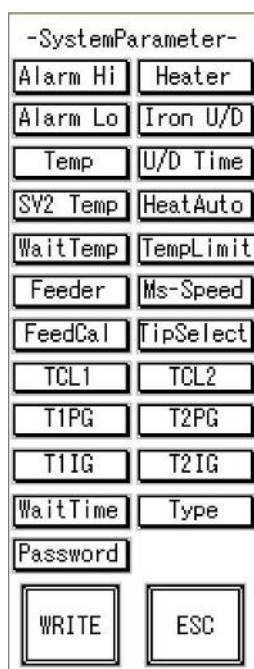

Parameter selecting screen

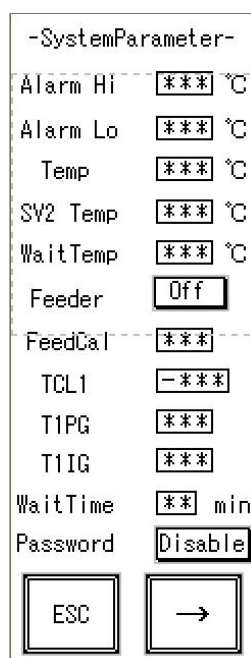

Parameter setting screen

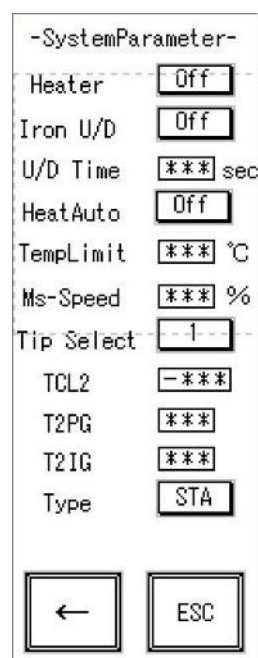

Parameter setting screen

## Initial setting (Factory setting) system parameter

Command	Initial setting		Adjustable range		Detail
Alarm Hi	50		0 - 200		Temp. alarm range High
Alarm Lo	50		0 - 200		Temp. alarm range Low
TEMP	100		1 - 500		Setting temperature
SV2 Temp	300		1 - 500	ON/OFF	SV2 temperature setting
Wait Temp	100		1 - 300		Stand by temperature setting
Feed		ON		ON/OFF	Solder feed : Enable/Void
Heat		ON		ON/OFF	Heater : Enable/Void
Iron U/D		ON		ON/OFF	Iron up/down sensor: Enable/Void
U/D Time	3	ON	0 - 99	ON/OFF	Iron up/down sensor error limit
Heat Auto		ON		ON/OFF	Heater auto start when power on.
Tem Lim	500		100 - 500		Maximum temperature
Ms-Speed	250		1 - 250		Manual solder feeding speed
Feed Cal	80		1 - 200		Auto solder feeding quantity adjust
TIP	1		1/2		Tip select 1 or 2
TCL1	-30		±100		Tip type 1 temperature calibration
TCL2	-30		±100		Tip type 2 temperature calibration
T1PG	30		1 - 200		Tip type 1 Proportion Gain
T1IG	99		0 - 99		Tip type 1 Integral Gain
T2PG	100		1 - 200		Tip type 2 Proportion Gain
T2IG	80		0 - 99		Tip type 2 Integral Gain
Wait time	30	ON	0- 60	0 input :OFF	Wait time (min.) Enable/Void
Password		Disable		Enable/Disable	Screen lock, 4 digit
Type		STA	STA/ROB		Required emergency signal STA: Break contact ROB: Normal contact

- When Type is switched, restart TERRA by switching on and off after writing.  
Use STA, except for combining APOLLO SEIKO robot.
- Input calibration value to TLC1, when measured value differs from display value.  
Input value can be calculated by the below formula.  
  
Input value = (Measured value – Display value) + Existing value  
  
e.g) Display value 300°C, Measured value of iron tip 280°C  
(280°C - 300°C) + 0 = -20°C    Input -20°C
- Wait Temp interlocks Wait time. When Enable is turned ON, input the proper value to both of Wait Temp and Wait time. If “0” is input, the wait time is disable.
- When the screen lock is set “Enable”, the password screen is displayed.  
Input 4 digit number and push “Write”.

Contact Apollo Seiko, if you have forgotten your password by any chance.



## 6. Operation

---

### 6.1 Preparation

Make sure the following matters before the operation.

1. Check the power supply, the connections of the power supply, air pressure, the voltage and air pressure (The suitable pressure is from 4 to 7 kg/cm<sup>2</sup>).
2. The diameter of the solder wire is correct and the wire is sufficient.

### 6-2 Order of operation

1. Turn ON the TERRA power supply. (Make sure the lamp for Power ON is on.)
2. Attach the solder wire with the following order.

### 6.3 Set of solder wire

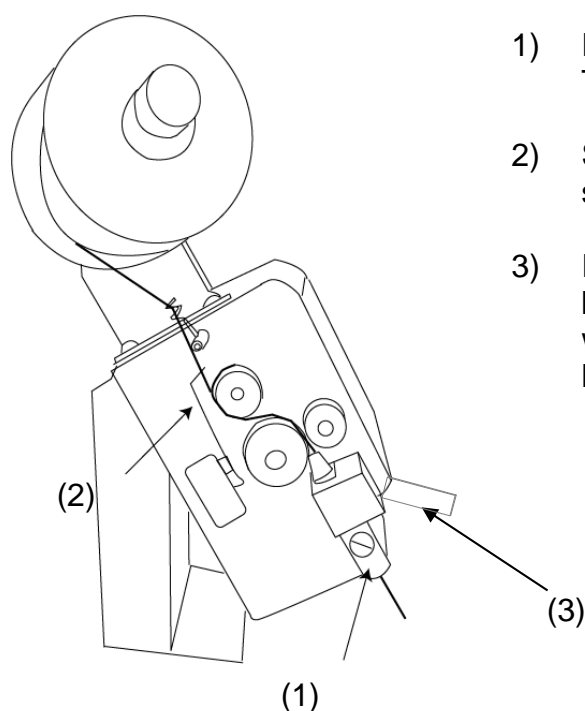

- 1) Remove the tube and pull solder wire through first. Then attach the solder tube.
- 2) Set the solder wire as per the diagram. And make sure to set solder wire on the shortage sensor.
- 3) If the release lever is upper position, the cutting blade/pinch roller does not feed a solder wire. So, when you would like to feed the wire, put down the lever before.

### 6.4 Turn on the robot power

1. Turn ON the Robot power supply and press Start button.
2. The screen changes to green color after while and shows the operation screen. If not check the air supply and the iron cartridge.
3. Press the start button and one cycle operation will start.

6.5 How to adjust RSP iron unit

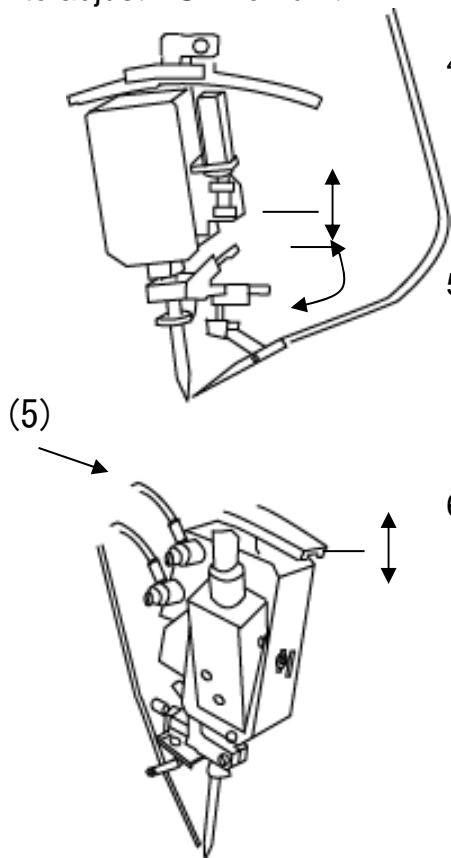

4) Solder wire feeding position can be adjusted.

Upper adjusting screw: Up down direction  
 Lower adjusting screw: Side way direction

5) Iron up down speed can be adjusted by turning screws after undoing nut.

Upper black screw: Raising speed  
 Lower white screw: Go down speed

6) Second solder feeding position can be altered by moving this screw. Adjusting the screw position, First solder wire can be put between the iron tip and a solder pattern.

Move it to lower: The same feeding positions.  
 Move it to upper: The second feeding position become higher and the first solder would be melt down between the iron tip and a solder pattern.

## 7. Input and output wiring diagram

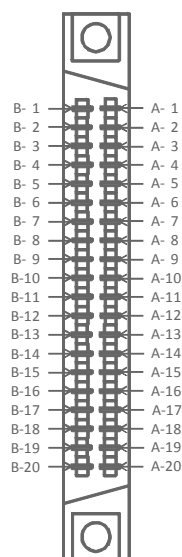

<Connector>

TERRA side

FUJITSU FCN-361J040-AU

Cable side

FUJITSU FCN-361P040-AU

### Connector terminal pin allocation

Left side		Right side	
B-1	EMR	A-1	EMR
B-2	READY	A-2	SEL1
B-3	RUNNING	A-3	SEL2
B-4	END	A-4	SEL4
B-5	ACK	A-5	SEL8
B-6	SOLDER ERROR	A-6	SEL16
B-7	IRON UNIT ERROR	A-7	SEL32
B-8		A-8	SEL64
B-9		A-9	
B-10		A-10	START
B-11	AUX OUT	A-11	STOP
B-12		A-12	RESET
B-13		A-13	S+
B-14		A-14	S-
B-15	24V	A-15	IRON U/D
B-16	24V	A-16	AIR BLOW
B-17	EXT 24V	A-17	SEL100
B-18		A-18	SEL200
B-19	0V	A-19	LINE MOVE END
B-20	0V	A-20	

## Input

Pin No.	Terminal name	Signal name	Description	
A-1	EMR	Emergency stop	The machine stops at emergency. Usually it is used ON of no voltage.	
B-1			If this terminal is released, all of the soldering operation stops and the heater is turned OFF. After shortening, input the reset signal.	
A-2	SEL1	Prog. select 1	Select soldering condition number.	
A-3	SEL2	Prog. select 2	Set soldering condition number combining with A-17 SEL100, A-18 SEL200 by binary number. It is set by ON. 000 Cleaning WK100 101~199 Point soldering WK101~199 201~299 Slide soldering WK201~299 301~399 Special soldering WK301~399  Setting example Cleaning WK100: All OFF Point soldering WK101: SEL100 and SEL1 ON Slide soldering WK205: SEL200, SEL1, SEL4 ON	
A-4	SEL4	Prog. select 4		
A-5	SEL8	Prog. select 8		
A-6	SEL16	Prog. select 16		
A-7	SEL32	Prog. select 32		
A-8	SEL64	Prog. select 64		
A-10	START	Start signal		It starts automatic operation. Signal is input by the sensor, switch, etc. (Minimum pulse width is more than 100ms.) When READY output is ON, it accepts input.
A-11	STOP	Stop signal		Automatic operation stops. (Minimum pulse width is more than 100ms.)
A-12	RESET	Reset signal	It returns from Emergency stop or Error condition. Input the signal after releasing Emergency stop or Error condition. (Minimum pulse width is more than 100ms.)	
A-13	S+	Solder feeding forward	It feeds solder wire forward from the feeder. Feeding speed can be set by Ms-speed of the system parameter. (Do not input ON at the same time of A-14.)	
A-14	S-	Solder feeding reverse	It reverses solder wire to the feeder. Reverse speed can be set by Ms-speed of the system parameter. (Do not input ON at the same time of A-13.)	
A-15	IRON U/D	Iron unit up/ down	It operates the iron unit up and down. ON: iron down OFF: Iron up	
A-16	AIR BLOW	Air blow	It operates air blow for tip cleaning at ON.	
A-17	SEL100	Prog. select 100	Select soldering condition number combining with A-2 ~ A-8. When A-17 is ON with A-2 ~ A-8, 100 is added. When A-18 is ON with A-2 ~ A-8, 200 is added. When both A-17 and A-18 are ON, 300 is added.	
A-18	SEL200	Prog. select 200		
A-19	LINE MOVE END	End of slide soldering	It stops Easy Line soldering of Special soldering.	
B-17	EXT 24V	External power supply input	24V input for external power supply. When you use this input, open the side cover and slide DIP switch on the circuit board to the external input side. The DIP switch is set as internal power supply at factory setting. Use exclusive GND (B-19,B-20) to connect to GND.	

## Output

Pin No.	Terminal name	Signal name	Description
B-2	READY	Ready signal	It turns on, when automatic operation is ready.
B-3	RUNNING	Running signal	It turns on during automatic operation.
B-4	END	Operation end signal	It turns on when automatic operation ends. (ON time approx. 100ms)
B-5	ACK	ACK output	It outputs the timing of axis moving at slide soldering. It turns ON, after the time that is set on STEP 4 ACK of WK setting.. (ON time approx. 100ms)
B-6	SOLDER ERROR	Solder error signal	It outputs at solder shortage or solder clogged. It automatically returns, when new solder wire is replaced at solder shortage. Remove clogged solder and input RESET signal at solder shortage.
B-7	IRON UNIT ERROR	Iron unit error signal	It turns on at normal state. Temperature error: it turns off, when the temperature exceeds temperature alarm range set on the system parameter. The display turns in orange color. The error is automatically released after the temperature is recovered.  Iron unit U/D: It turns off, when iron unit up/ down sensor does not work. Input RESET signal after error cause are solved.
B-11	AUX OUT1	External output 1	This output is for iron shot counter. It turns on at the end of the cycle excluding cleaning. (ON time approx. 100ms)
B-15	24V	DC24V output	It is DC24V output by internal power supply of TERRA. The max. power supply current is 500mA. Use exclusive GND (B-19,B-20) to connect to GND.
B-16			

Power supply DIP switch

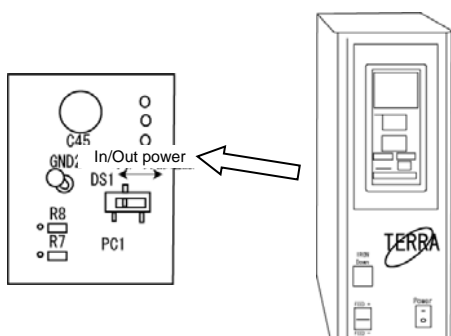

When you use the external power supply., open the side cover and slide DIP switch on the circuit board to the external input side.

\* DIP switch is set as internal power supply side at factory setting. It breaks when the external switch is connected when DIP switch keeps on the internal power supply side. Please be careful.

Internal circuit diagram (Pattern diagram)

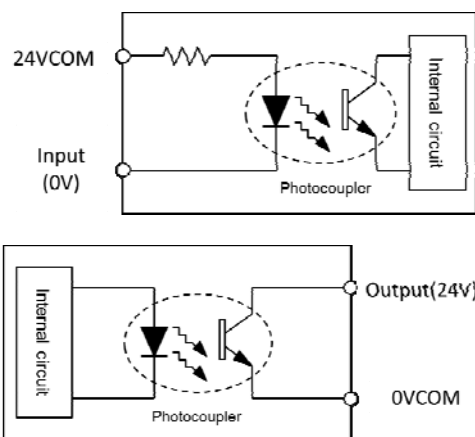

Use at DC24V, less than 100mA.

## 8. Timing chart

### Point soldering

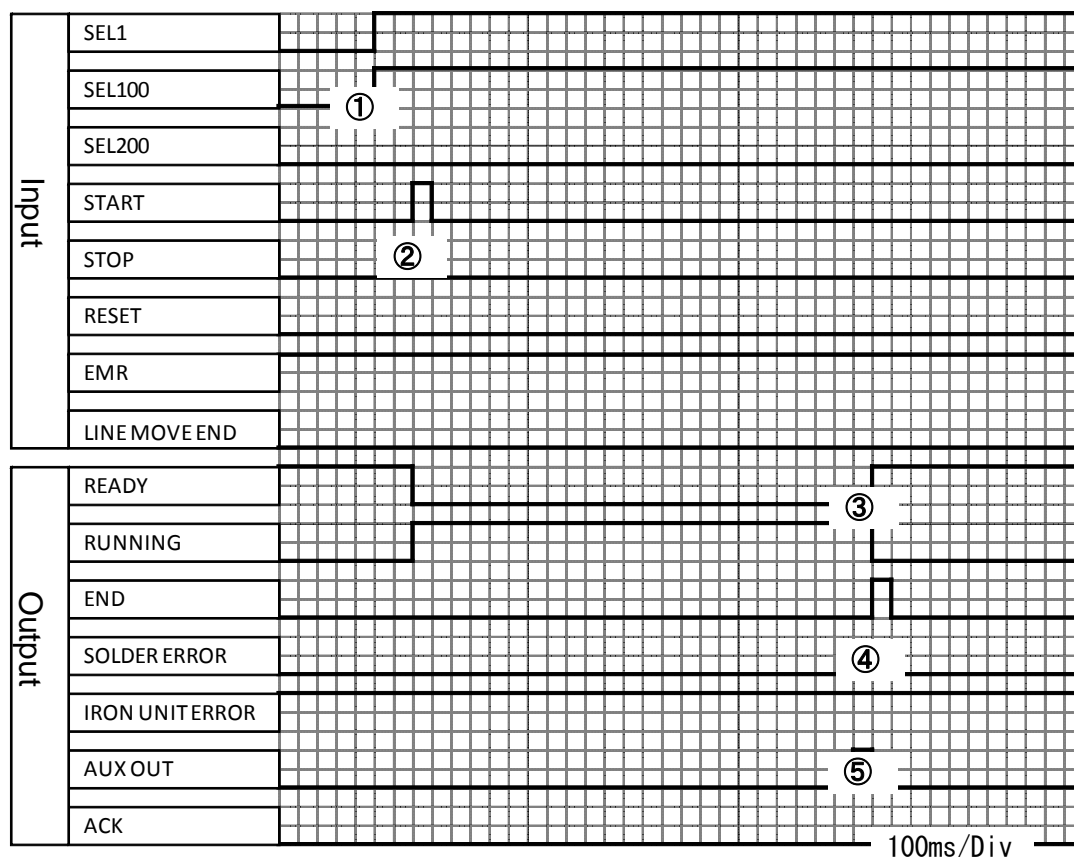

- ① Turn on the SEL signal for selection before turning the start signal. Turn it off after the RUNNING signal is turned on.
- ② When the start signal is turned on, the READY signal is turned off and the RUNNING signal is turned on. Then selected WK number by SEL setting is started automatically.
- ③ END signal is turned ON as soon as automatic operation is finished.
- ④ AUXOUT signal is turned ON just before END signal is ON.

## Slide soldering

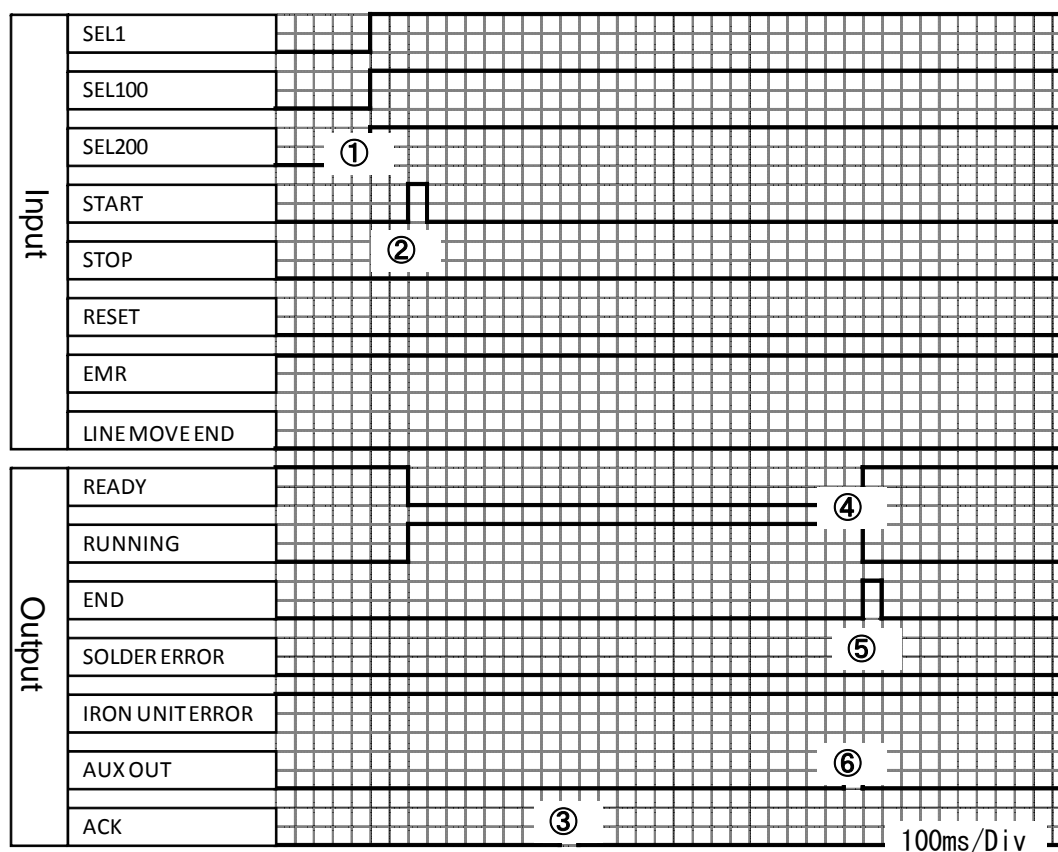

- ① Turn on the SEL signal for WK selection before turning the start signal.
- ② When the start signal is turned on, the READY signal is turned off and the RUNNING signal is turned on. Then selected WK number by SEL setting is started automatically.
- ③ ACK signal is turned ON when slide movement is started.
- ④ READY signal is turned ON and RUNNING signal is turned OFF when automatic operation is finished in order.
- ⑤ END signal is turned ON as soon as automatic operation is finished.
- ⑥ AUXOUT signal is turned ON just before END signal is ON.

## Easy Slide soldering

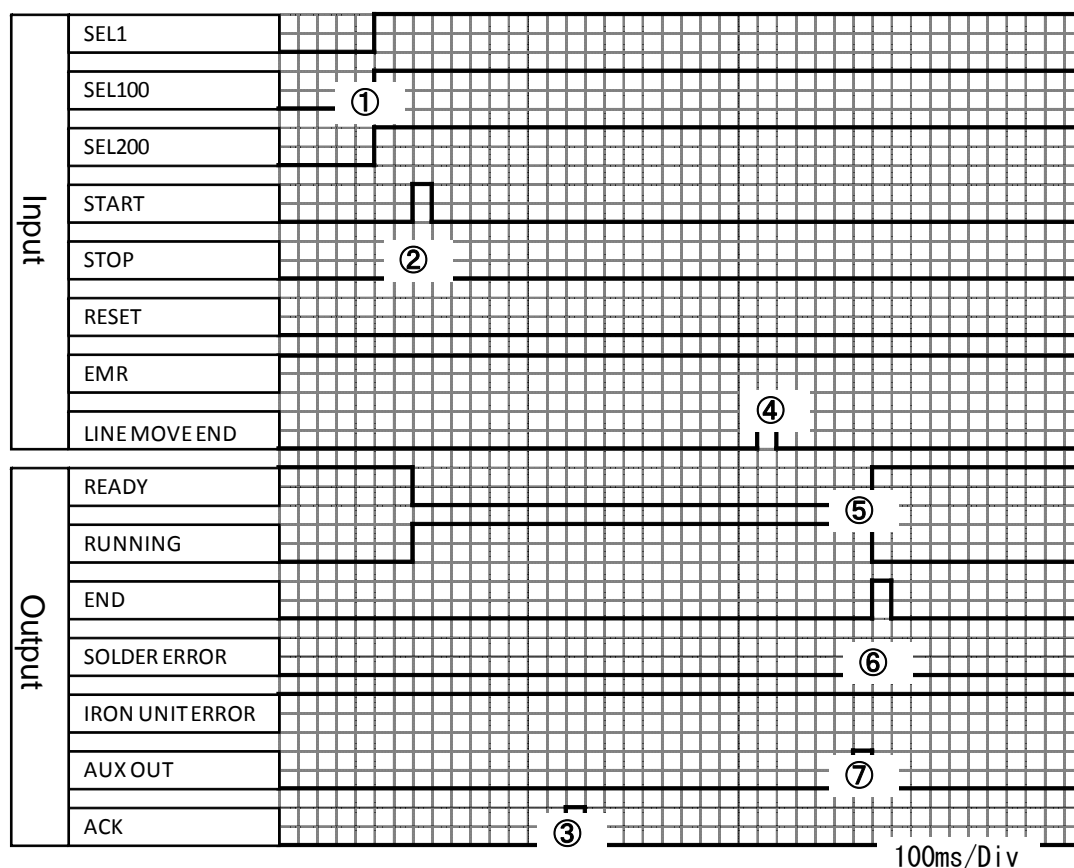

- ① Turn ON the SEL signal for WK selection before turning the start signal.
- ② When the start signal is turned on, the READY signal is turned off and the RUNNING signal is turned on. Then selected WK number by SEL setting is started automatically.
- ③ ACK signal is turned ON when slide movement is started.
- ④ Turn ON "LINE MOVE END" signal to stop Easy sliding solder.
- ⑤ READY signal is turned ON and RUNNING signal is turned OFF when automatic operation is finished in order.
- ⑥ END signal is turned ON as soon as automatic operation is finished.
- ⑦ AUXOUT signal is turned ON just before END signal is ON.



## Cleaning

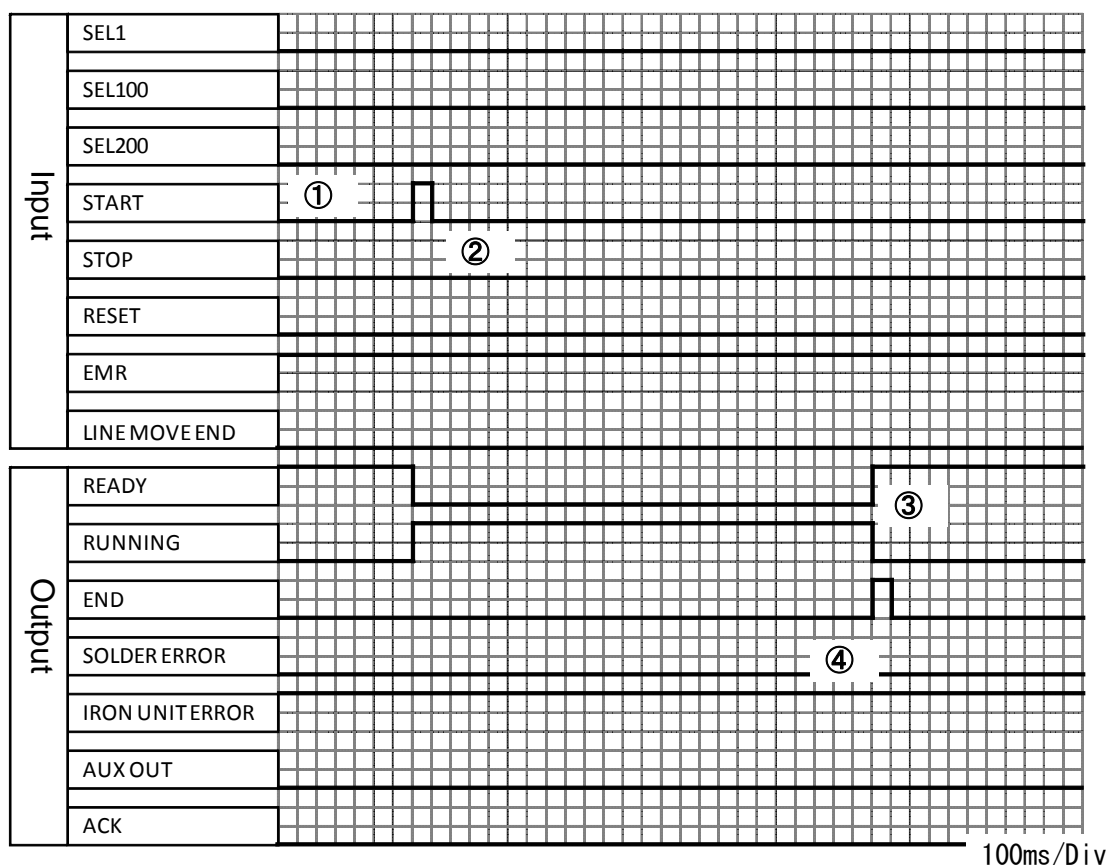

- ① Turn OFF the all SEL signals for WK selection before turning the start signal.
- ② When the start signal is turned ON, the READY signal is turned OFF and the RUNNING signal is turned ON. Then selected WK number by SEL setting is started automatically.
- ③ READY signal is turned ON after cleaning is finished in order.
- ④ END signal is turned ON when cleaning is finished however, AUXOUT signal is not turned ON.

# Stop operation

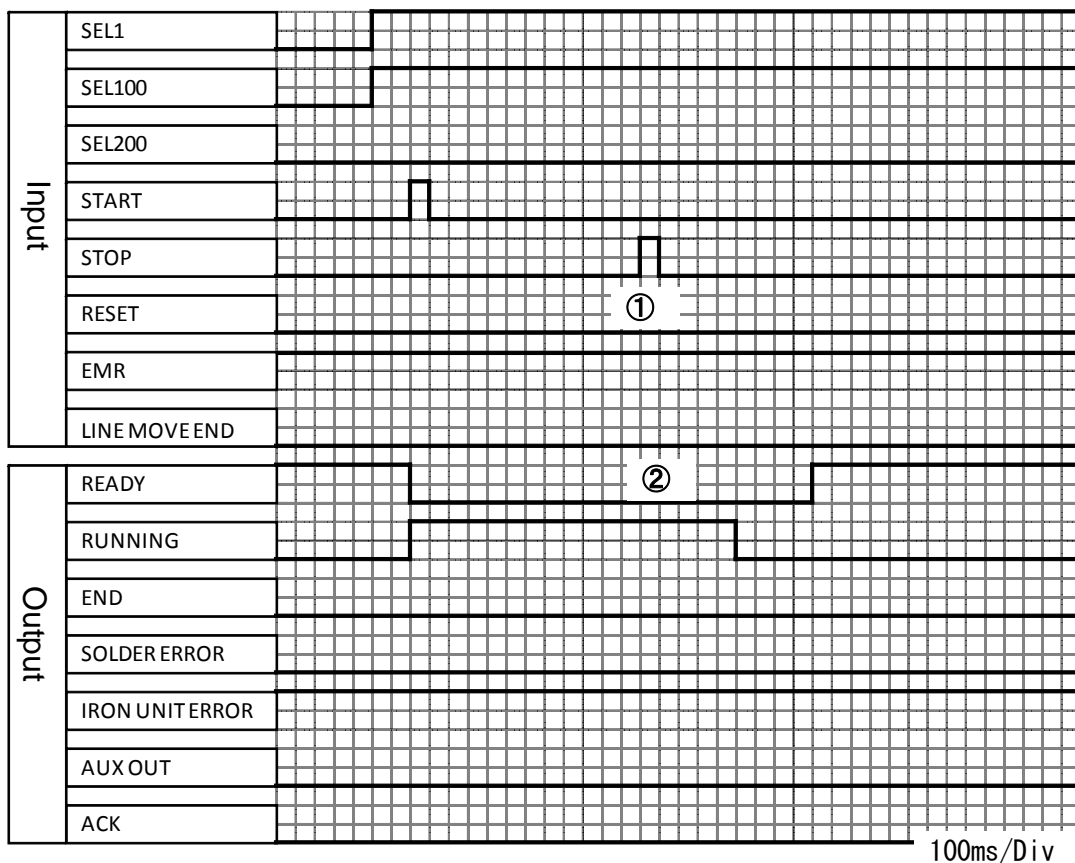

- ① If STOP signal is entered during automatic operation, soldering operation is stopped and RUNNING signal is turned OFF.
- ② READY signal is turned ON in 0.4 second (400ms) after.

## Emergency operation

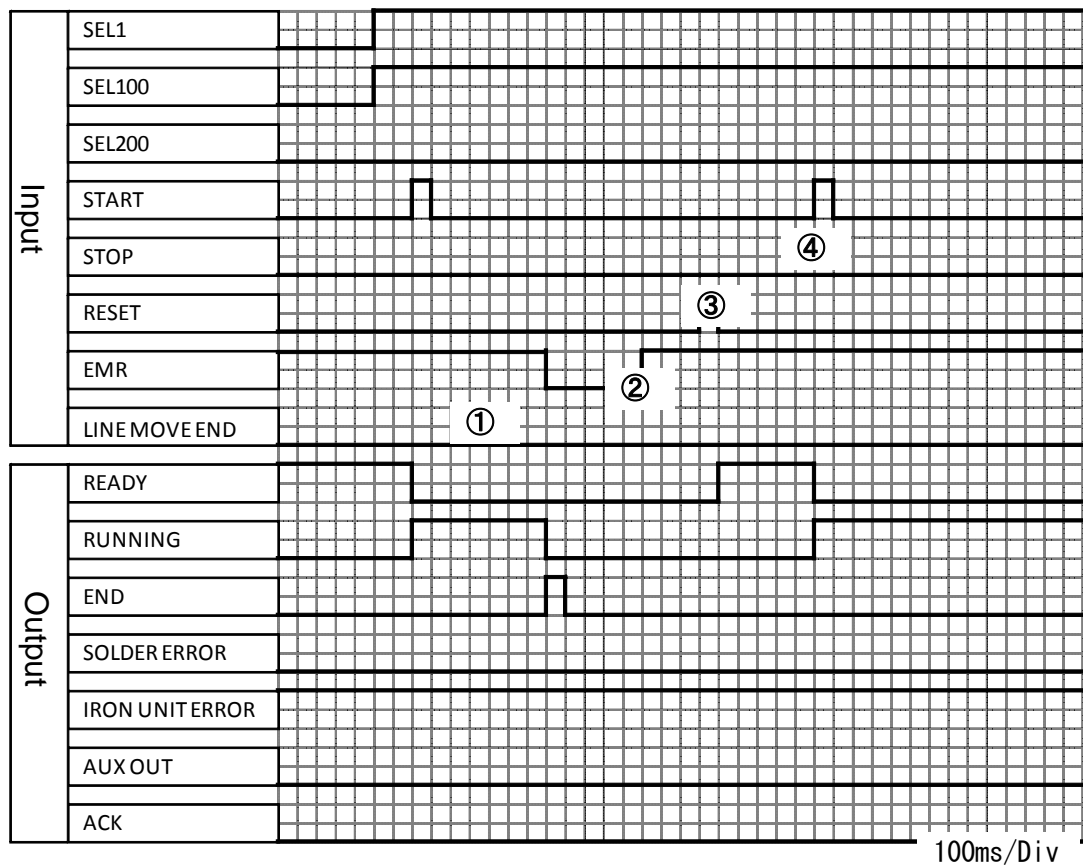

- ① If EMR signal is turned OFF during automatic operation, RUNNING signal is turned OFF and END signal is turned ON.
- ② To recover, turn ON the EMR signal.
- ③ Turn ON RESET signal to recover and READY signal is turned ON.
- ④ Automatic operation can be resumed to turn ON START signal if READY signal is ON.

## Solder Error

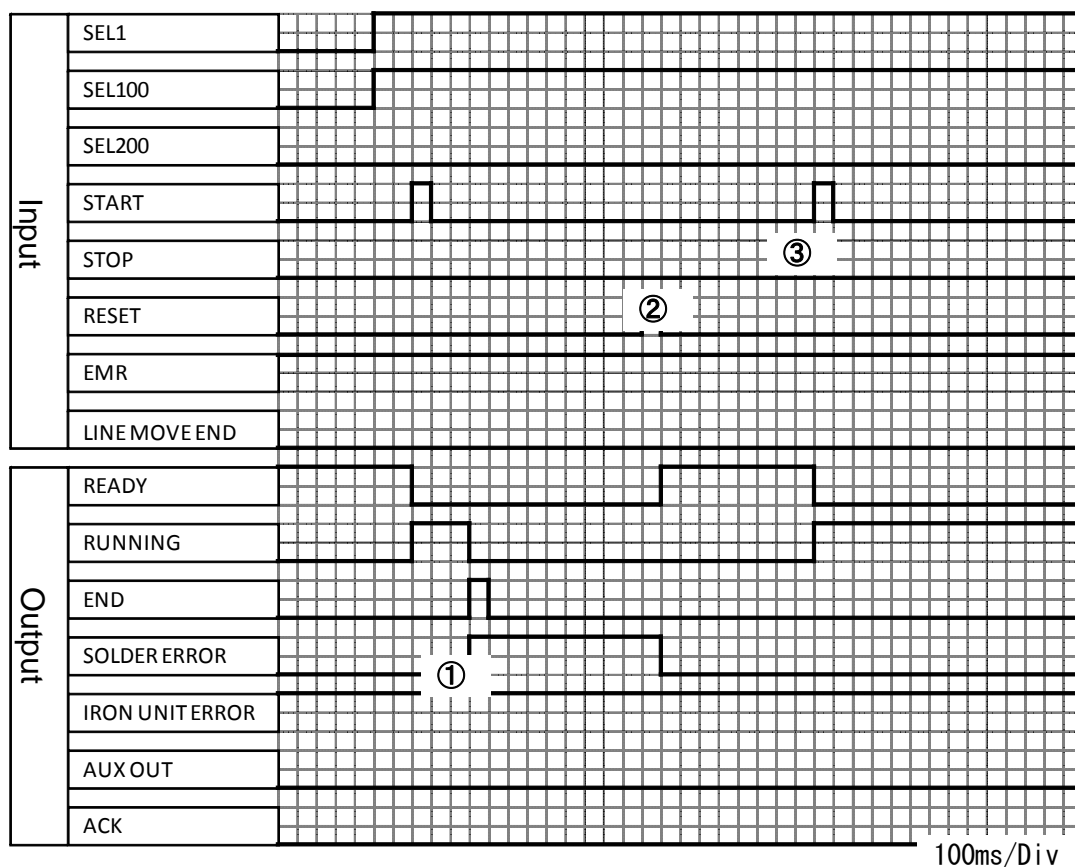

- ① SOLDER ERROR signal is turned ON if solder shortage and clogging error occurs during automatic operation. Then, RUNNING signal is turned OFF and END signal is turned ON.
- ② To recover, turn ON the RESET signal.
- ③ Automatic operation can be resumed to turn ON START signal if READY signal is ON.

## Iron unit error (Temperature)

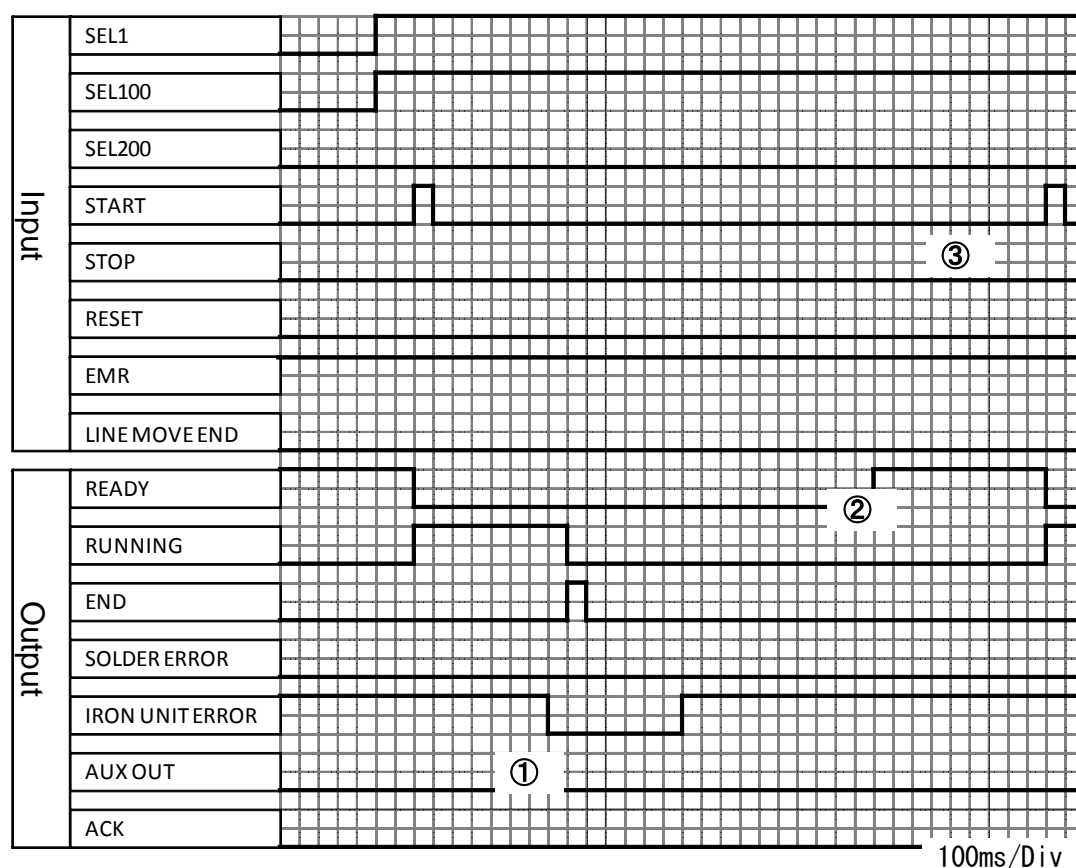

- ① IRON UNIT ERROR signal is turned OFF if solder tip temperature become out of high/low set range. Then, RUNNING signal is turned OFF and END signal is turned ON.
- ② IRON UNIT ERROR signal is ON when solder tip temperature is recovered. Then, READY signal is turned ON.
- ③ Automatic operation can be resumed to turn ON START signal if READY signal is ON.

### IRON UNIT ERROR (Sensor)

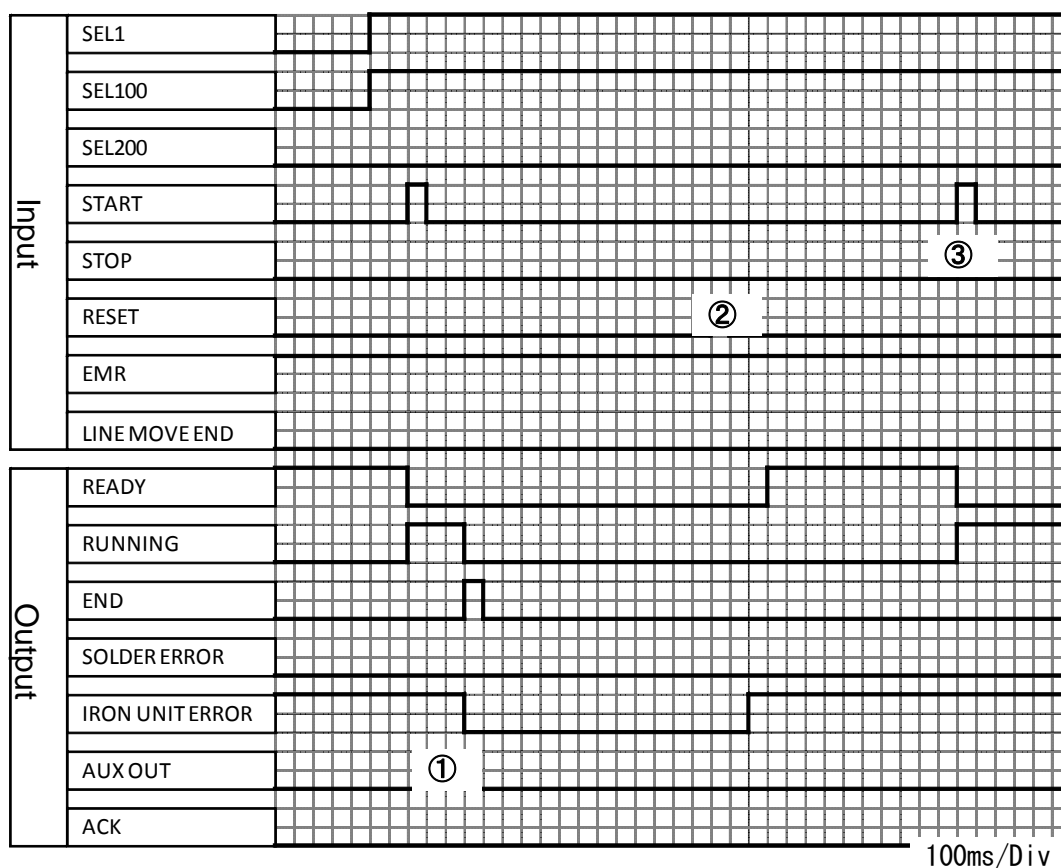

- ① IRON UNIT ERROR signal is turned OFF if iron unit up/down sensor is not turned ON within set time. Then, RUNNING signal is turned OFF and END signal is turned ON.
- ② To recover, turn ON the RESET signal.
- ③ Automatic operation can be resumed to turn ON START signal if READY signal is ON.

## 9. ZSB feeder adjustment and alignment (Option)

Adjust the ZSB feeder as follows

The cutting depth of ZSB blade must be adjusted properly to operate properly. Adjust and clean it every time before use.

(1) Remove the cover after loosening five setting screws.



(2) Loosen the set screw "1" for alignment cutting blade shaft and the setting nut "2" to adjust the shaft position. Then move the blade shaft position to match the center of the cutting blade and V groove of the lower roller.

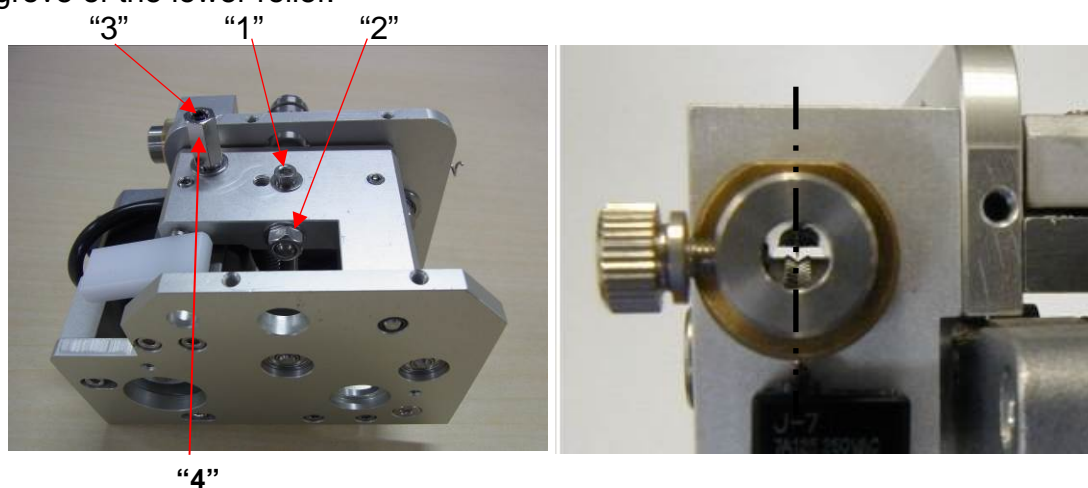

(3) Tighten the set screw "1".

(4) Attach the reel pin as it stays without the cover, and then set the solder wire.

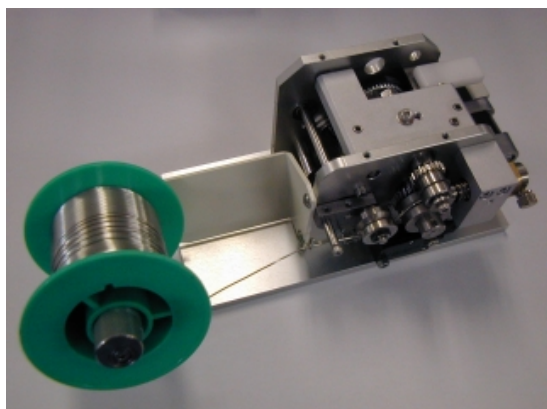

(5) Push down the forward/reverse lever and feed the solder wire, then make sure the cutting blade makes holes on the center of the solder wire. If the holes were not on the center, adjust the cutting blade shaft position, then feed the solder wire and check it.

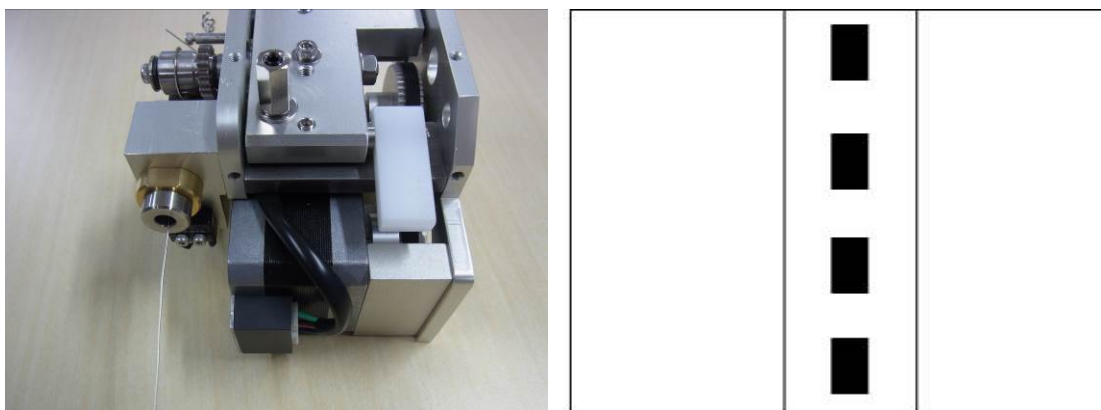

(6) Cut the solder wire with holes perpendicularly and check the cross section. Make sure the cutting blade penetrates into flux core.

If the cutting depth was not enough or too deep, loosen the nut "4" then adjust the adjusting screw "3" for the cutting depth to penetrate into flux core.

After that feed the solder again, cut the wire and check the cross section again.

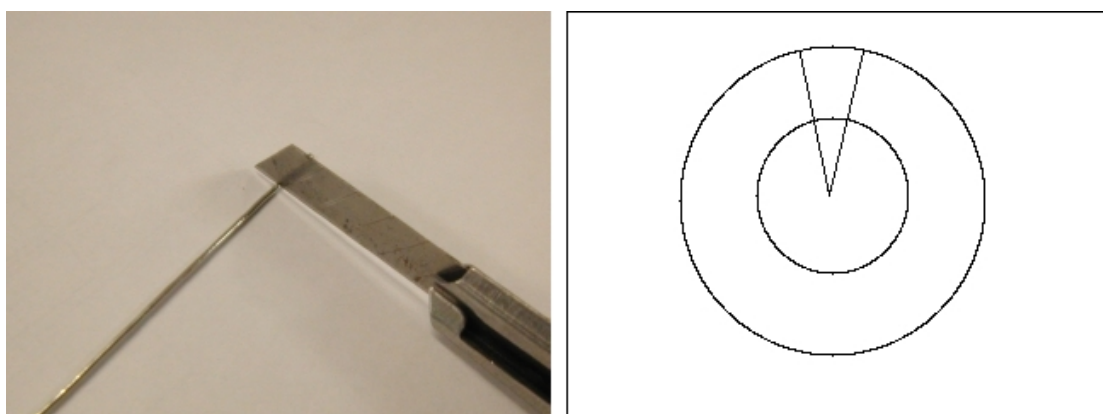

(7) Complete adjusting the alignment and depth of the cutting blade and increase the temperature of iron tip. Then, melt the solder wire with holes.

And make sure the flux is coming out from the holes.

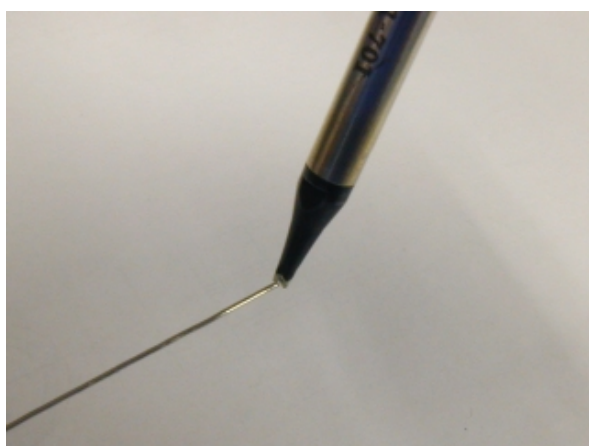

(8) Put back the cover and tighten five set screws.



## 10. Maintenance

---

- Daily inspection requirement items are as follows:

Note: when the inspection, turn off the power and cool down the iron tip.







- 1) Existence of solder wire:  
If the solder wire is not sufficient, please change to new one.
  - 2) Wear of iron tip  
If soldering result became unstable, please change it to new one. The life time of the iron tip is depends on the heating time, the solder feeding point and speed.
  - 3) Breaking of heater  
The causes of a breaking of heater when the lamp for indication of temperature error is on and the temperature controller is normal are as follows:
    1. The breaking of heater. Change the iron cartridge
    2. The breaking of the relay cord (CC-2F) Change the iron cord.
    3. The iron tip is worn. Change the iron cartridge
  - 4) Air pressure  
Make sure the air pressure if it is adequate. (0.5MPa)
  - 5) Clog of the tube set  
If the top (exit side) of the tube set clog by a flux or solder wire, please remove it and clean it with alcohol.
  - 6) Up/down movement  
Make sure if the up/down movement of iron unit is smooth. Also, make sure if there is no flux sticking in moving parts.
  - 7) Cutting blade and pinch roller for solder wire feeding  
Make sure flux or solder does not stick to the above parts. If so, clean it with a soft (brass) wire brush and alcohol.
- After every 5,000 points soldering  
Check the solder tip temperature with a thermometer.  
Refer to the page of temperature calibration.
  - Every month  
Make sure a solder wire run through the solder wire tube. If not, clean the inside of tube or replace.
  - Every year  
Send the thermometer to an authorized agent for the calibration

## 11. Trouble shooting

---

Problem	Failure reason	Recommended solution
TERRA is not receiving power	The power code is disconnected	Check the power cord connection
	Fuse is blown	Replace with a 3 Amp fuse
	Control PCB is damaged.	Contact Apollo Seiko or our agency for repair
The iron tip does not heat properly	Heater is broken.	Replace with a new heater
	Heater connector is disconnected.	Check the heater connection.
	Heater cable is broken.	Replace with a new heater cable.
	The tip is at end of life.	Replace with a new iron tip.
	Parameter setting is not proper.	Check the system parameter and input proper value.
Solder is not properly fed.	Control PCB is damaged.	Contact to Apollo Seiko or our agency for repair.
	The release lever is upper position.	Lower the release lever.
	The feeding cutting blade is idling	Adjust the position of cutting blade.
	Speed setting is '0'.	Check the system parameter.
	The motor is damaged.	Contact Apollo Seiko or our agency for repair.
The temperature controller cannot be adjusted.	Control PCB is damaged.	Contact Apollo Seiko or our agency for repair.
	Heater is broken.	Replace with a new heater.
	Heater cable is broken.	Replace with a new cable.
Temperature abnormality does not disappear.	Heater cable is disconnected.	Check the cable connection.
	Upper/ lower temperature alarm value is not proper.	Check the system parameter and enter proper value.
Iron unit does not move up/down.	Air is not supplied to the unit.	Check air supply.
	Control PCB is damaged.	Contact Apollo Seiko or our agency for repair.
TERRA does not work from inputting I/O.	The type of system parameter setting is wrong.	Set type " STA", except for combining APOLLO SEIKO robot.

## Error Sign List

Error Display	Description	Failure reason	Recommend solution
 EMERGENCY	Inputting the emergency stop signal	Emergency stop switch turns ON	Turn OFF the emergency stop switch.
		Defective connection of I/O connector.	Connect the I/O connector properly.
		Breaking I/O cable	Replace or repair I/O cable.
		Mismatch of type setting and emergency stop signal	Change the contact of type setting or emergency stop signal.
 HEATER ERROR	Detect the error of heater	The iron cartridge doesn't insert.	Make sure whether the iron cartridge insets properly.
		Breaking of the heater	Replace with a new iron cartridge.
		Thermocouple is damaged.	
		Low/high values of temperature alarm are incorrect.	Input the proper value in the system parameter.
 SOLDER SHORTAGE	End of the solder feeding	Release lever is upper position	Put down the release lever.
		End of the solder feeding	Replace with a new bobbin.
		Misdetection of the sensor	Check the solder wire is set properly.
		The sensor of solder feeding is damaged	Contact Apollo Seiko or our agency for repair.
 SOLDER CLOGGED	Detect the solder clogged	Solder tube is clogged with solder wire.	Replace a new solder tube.
		Solder wire does not melt properly.	Slow down the speed of solder
			Adjust the position of solder feeding.
 UPPER SENSOR TIME OVER	Upper sensor of iron unit or air cylinder does not detect properly.	Air is not supplied.	Supply the air.
		Air pressure goes down.	Check the pressure of the air.
		Air leakage or tube is not jointed.	Make sure whether there is the air leakage or not from air hoses or a part of connection.
		Regulation of the cylinder speed controller is not adjusted.	Regulate the speed controller properly.
		Upper sensor of air cylinder is damaged.	Contact Apollo Seiko or our agency for repair.
 UPPER SENSOR TIME OVER	Lower sensor of iron unit or air cylinder does not detect properly.	Air leakage or tube is not jointed.	Make sure whether there is the air leakage or not from air hoses or a part of connection.
		Regulation of the speed controller is not adjusted.	Regulate the speed controller properly.
		Sensor of air cylinder is damaged.	Contact Apollo Seiko or our agency for repair.

## 12. Handling and Care of Iron Tip

---

### Introduction

Soldering is a technique which connects a metal to another metal by alloy reaction.

Solder material melts, but mother material (metal pieces on the work-piece) never melt by soldering.

There are three important factors (Three great factors of soldering) for the alloy reaction as follows:

Cleaning the metal surface

Formation of alloy layer which by melting solder and connecting to metal surface

Heat source which should be maintained in suitable temperature in order to form alloy layer by soldering.

Solder iron tip is related to the formation of alloy layer and the heat source.

So, It is very important for a good care of solder tip to make a stable soldering.

### <Handling of iron unit>

Apollo soldering tip, HI-TIP (AS, HQ, TM and DC model) realized the high performance and long life by using oxygen-free copper as a mother material with special iron plating and careful after treatment.

Usually, the life of the tip is about 50,000 points. However, if it is used at more than 400°C or if solder with a bad solder feeding position, the life is shorten extremely to approximately 5,000 points caused by "Iron plate Corrosion". Therefore, please use it with suitable condition. If the condition is proper, the life exceeds 100,000 points.

1. Attach an iron tip, then the vinyl resin coating on the iron tip is cracked and peel off during the temperature rising. Please use it after making pre-soldering by the solder including flux.
2. Iron tip should be placed at iron stand after pre-solder on iron tip. If tip is left at the stand without solder after cleaning, the tip oxidizes and cannot be getting wet with solder.
3. If flux or some oxide residues were left over the iron tip, please remove them with back of a cutting edge like a cutter lightly.

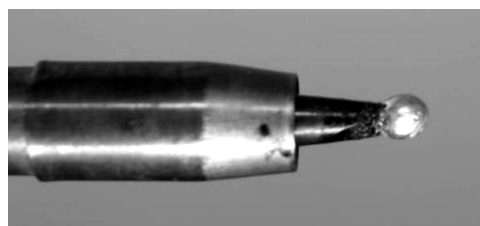

Do NOT file the iron tip because iron plating may be peeled off, then the iron tip cannot be getting wet with solder.

If a tip is not getting wet with solder.....

Remove pre-solder on tip completely.

Brush the iron tip lightly with a brass wire brush.

Melt a new solder including flux on the tip or dip the iron tip into a soldering pot.

Remove the needless solder with a wet sponge.

Make pre-solder soon

The tip will wet with solder by the above process.

**<Care of Iron tip>**

## 1) Check iron tip by eyes every fixed time

Oxide is left on the iron tip.	Study of the number of air blow cleaning.
"Solder rise" exceed the solder plated area.	A malfunction is occurred by leavening a corrosion by chloride element in flux. Replace the iron tip.
Bad solder flow	Remove pre-soldering on the iron tip completely. Cool it to room temperature and remove oxidation by a sand paper. Then turn it on again and make pre-soldering to the iron tip surface during rising temperature.
Transformation of iron tip	Need to change of iron tip by the corrosion of chloride element in flux and wear phenomenon.

## 2) Check for soldering defect

Imperfection of electric connection by of flux membrane.	Clean the surface and make iron tip temperature high and heating longer.
Rough soldering surface	This defect occurs if the heating temperature is high or low. Adjust it to proper temperature.
Soldering removes and comes off because the solder does not melt.	Shortage of heat
Solder flow	A malfunction is occurs if the heating temperature is high, the heating time is long or the exceeding solder feed amount is supplied.

There are many solder defects except the above mentioned as follows:

"Solder shortage", "Icicle", "Solder excess", "Burning film" etc.

Please select suitable condition by seeing through the solder states.

## 13. How to change iron tip

DCS-\*\*\*, DCN-\*\*\*type

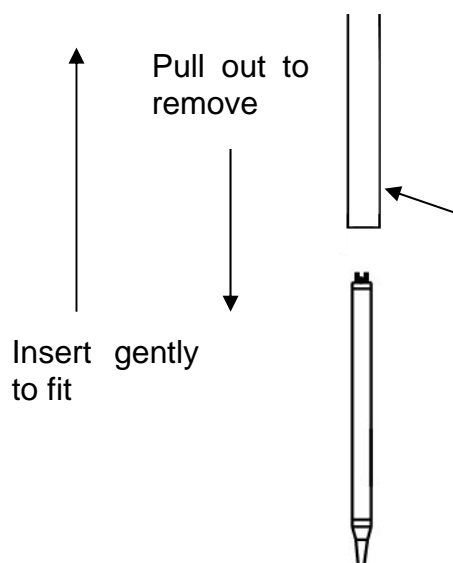

Make sure to turn the power off and cool down the temperature of iron cartridge pipe and pull down the iron cartridge to replace the new one. If it does not come out, using silicone tube pull it down strongly.

Key position

To attach a new one, insert it gently until the holder end. Then turn it until you feel the position key in the position. When you feel a clicking, insert it firmly. Do NOT turn the iron cartridge while the key is not in the position or the key is damaged.

DC-X type, X-\*\*\*

Make sure to turn the power off and cool down the temperature of iron cartridge. Then pull down the iron cartridge. Next pull out the iron tip. At this time, if cannot pull out, pull out with pushing the flat spring as follows.

When replace with the new one, make sure the tip getting a burning inhibitor. Then adjust the position and insert it strongly.

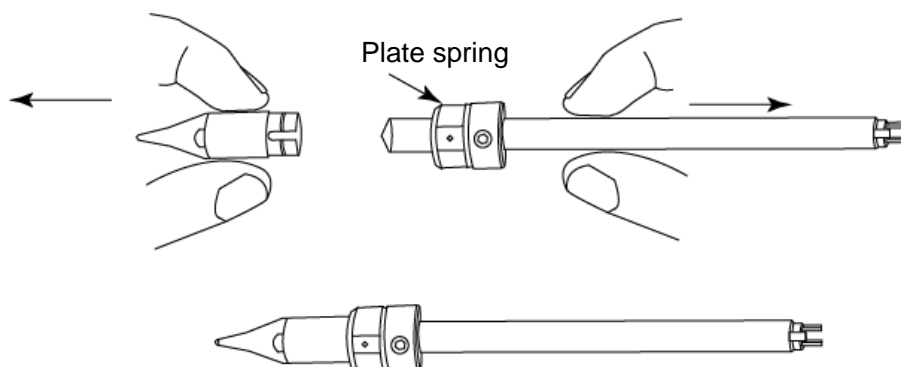



**Apollo Seiko Ltd.**  
2271-7 Jinba, Gotenba-shi,  
Shizuoka, Japan 〒412-0047

**TEL: +81-(0)550-88-2828**  
**FAX: +81-(0)550-88-2830**  
**E-mail: [sales@apolloseiko.co.jp](mailto:sales@apolloseiko.co.jp)**  
**URL: <http://www.apolloseiko.co.jp>**