



# Micro Soldering Laser Unit MLU-808FS

## Instruction Manual

**Thank you for purchasing the JR-MLU-808CS/FS.  
Read these instructions thoroughly for proper use of this machine.  
Make sure to read "Safety Notes" before you use machine.  
This information protects you from possible dangers during use.**

**Apollo Seiko Ltd.**

Rev. 1.00

## Safety Notes

This manual includes the important information to use machine safely. This also includes useful information to prevent avoiding injury or damaging property.

Please read this manual carefully prior to connecting or operating the JR-MLU-808CS/FS. Keep this manual nearby the machine all the time.

### Supply only specified voltage

- Do not connect to a power supply greater than the specified voltage. If not, electrical shock and /or damage to the unit may occur.
- Make sure that the electrical outlet is properly grounded. If the outlet is not properly grounded, electrical shock and/or damage to the unit may occur.

### Working ambient temperature and relative humidity

- This machine have been designed to use between 0~40 degree、10%~90%. Do not use this machine under the condition exceeding here-in.
- Do not put this machine in humid and dusty place.

### Handle with care

- This machine is designed to use laser soldering. If laser irradiation touch your skin or eyes, it may harm or burn you. So make sure put on laser protection glasses or laser douser.
- Please handle this machine with care. If you drop or make a big impact/ vibration, it may cause malfunction. Also do not close the vent. Please place this machine properly.

### If you do not use the machine for a long time

- Please turn off all of the power, remove all the power cable and keep it in dry and cool place.

### If you note malfunction on machine

- If the machine become a malfunction, turn off the power immediately and contact a dealer you purchased machine from.

### Immunity from responsibility

- We do take NO responsibility on a damage caused by misuse, mistake, accident, uses in abnormal condition or natural disaster such as an earthquake, a fire etc.
- We do take NO responsibility on contingency loss (Business loss、Business stop) caused by machine stop.
- We do take NO responsibility on a loss caused by the operation not mentioning on this manual.
- We do take NO responsibility on a loss caused by a wrong connection with other equipment.

If for any reason the internal circuitry is tampered with altered or repaired without written consent of Apollo Seiko, the warranty is null and void. The customer is allowed to make necessary tooling adjustment and make any necessary adjustments to the temperature controller.

## **Warning & Attention**

### **1. Laser safety class**

This machine is classified as a CLASS 4 LASER.

Laser synchrotron radiation and scattered light are very dangerous.

There are risks of exposure to your eyes or skin.

### **2. Wear laser protection glasses or use laser douser.**

During laser irradiation output lens irradiates strong laser light.

Reflected light from the workpiece may harm your eyes or skins.

Please make sure to put on laser protection glasses or use laser douser and be careful that laser light does not touch directly human body .

### **3. DO NOT look at the laser light.**

During laser irradiation, output lens irradiates strong laser light, DO NOT look at the light.

Reflected light from the workpiece may irradiate your eyes or skins.

### **4. DO NOT disassemble.**

Decomposition can cause a malfunction. Please do not ever disassemble this machine.

In particular, if you disassemble during laser irradiation, it is very dangerous laser light may leak.

When you notice abnormal operation,

- Stop operation immediately
- Turn off all of the switch on the machine
- Unplug all the cables
- Contact to Apollo Seiko or distributors.

### **5. High voltage caution**

Before supplying power, make sure all the cables are connected properly.

Electrical shock and/or damage to the unit may occur, if you connect or disconnect the connector in the enclosure during power supplying.

### **6. Handle with care**

This machine is precision optical equipment. Please handle this machine with care. If you drop or make a big impact/ vibration, it may cause malfunction.

Especially optical element in the laser unit is microadjusted.

If any shock is given to the laser unit, optical axis may be shifted and its characteristic may be lost.

### **7. Power ON / OFF**

Please follow the instruction when you power on / off the machine.

In particular, if you immoderately shut down the machine, it may cause failure.

Please DO NOT power off during operation besides emergency.

### **8. Connector protection**

For connector protection, please reduce the time of connecting/disconnecting the connector.

Please do not close anything excepting for cleaning tool to the connector outlet as possible.

When plug/unplug the connector, make sure to hold the plug.

If you pull from the electric cord, it may break wire.

### **9. Regular cleaning and Maintenance**

Please clean the machine regularly. If the air cooling fan in the machine is clogged, internal temperature rises and it may cause malfunction or failure.

**INDEX**

---

Safety Notes .....	2
INDEX .....	4
LD coaxial head • LD generator unit .....	5
1. Summary .....	5
2. Constitution .....	5
3. LD coaxial head .....	5
3-1. Dimension .....	5
3-2. Main specification .....	6
3-2. Description .....	6
4. LD generator unit .....	7
4-1. Dimension .....	7
4-2. Main specification .....	7
4-3. Description .....	7
5. Installation and connection .....	8
Power supply unit .....	10
1. Summary .....	10
2. Dimension .....	10
3. Specification .....	11
4. Description .....	12
5. Connection .....	14
6. Notice .....	15
7. Basic operation .....	15
8. Operating procedure .....	16
9. Remote mode .....	22
10. Function .....	28
11. Pin Assignment .....	30
12. Temperature controller .....	32
13. Parameter of factory setting .....	33
14. Alarm display .....	34
15. Troubleshooting .....	35
16. Maintenance .....	36
17. Protection function .....	36
18. Block diagram .....	37

# LD coaxial head · LD generator unit

## 1. Summary

This unit (MLU-808FS) is the micro soldering unit which makes easier to arrange with various robots and other equipment by downsizing and lightening the laser irradiation part of our independently developed optical system.

The LD light of wave length 808nm is combined to one fiber, and high density LD light is oscillated.

The coaxial head unit makes it possible to monitor LD light and application for fine positioning.

Also LD output can be controlled with the program function of the power supply unit.

## 2. Constitution

LD coaxial head	Main body	1 set
	Coaxial observation unit	1 set
LD generator unit	Main body	1 set
LD power supply unit	Main body	1 set
	Switch key	2 pcs
Image unit	CCD camera	1 set
	Line generator	1 set
	LCD monitor	1 set
Other equipment	Laser protection glasses	1 set

## 3. LD coaxial head

### 3-1. Dimension

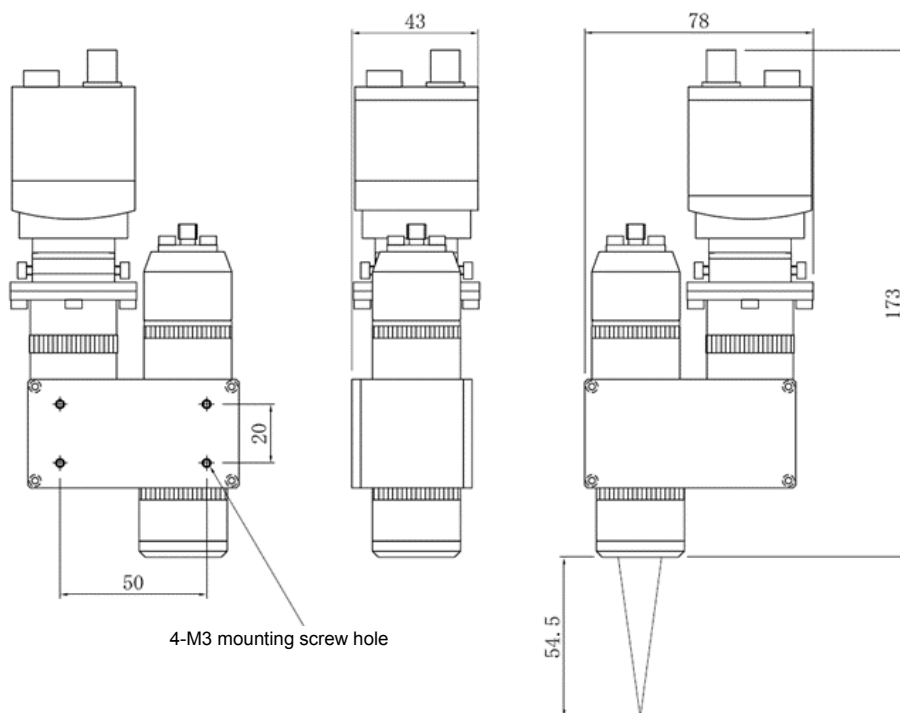

### 3-2. Main specification

Beam diameter	One select from $\phi 0.1\text{mm} \sim \phi 4\text{mm}$
Beam shape	Round
Coaxial optical system	Beam splitter system
Focal length	Abt. 10mm~200mm Depending on beam diameter
Working distance	Depending on focal length
Dimension	Approx. 78 (W) $\times$ 43(D) $\times$ 173(H)
Weight	Approx. 0.5kg

### 3-2. Description

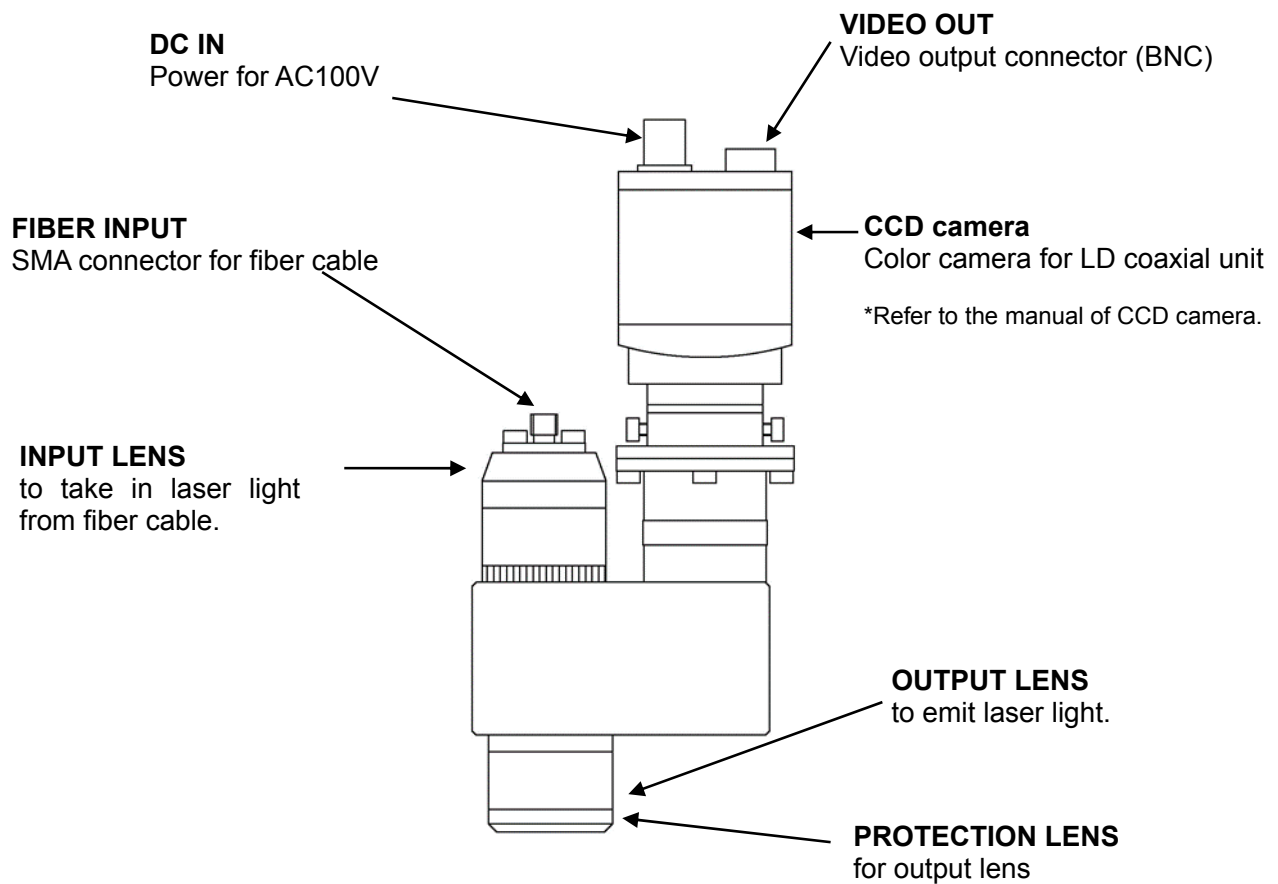

## 4. LD generator unit

### 4-1. Dimension

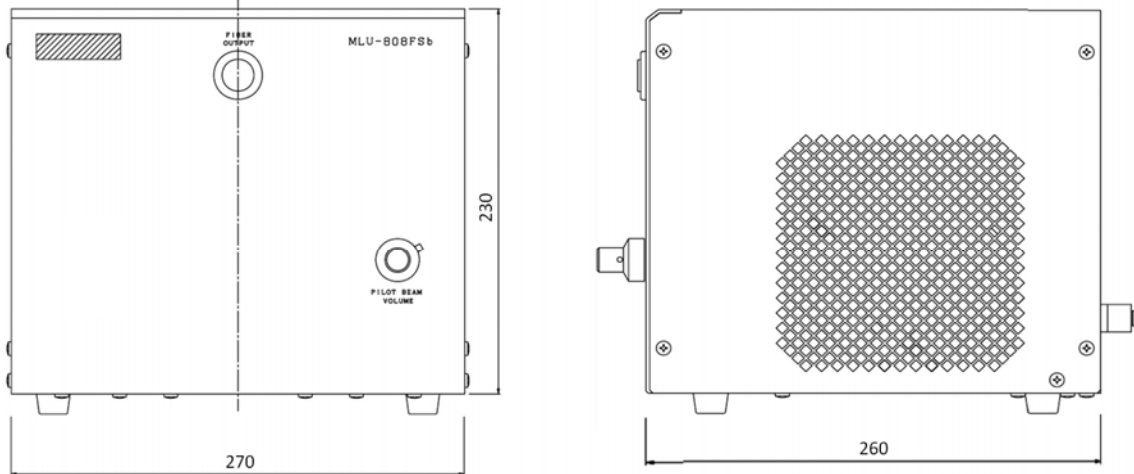

### 4-2. Main specification

Medium	Semiconductor laser
Wave length	808nm
Oscillation	CW (Continuous Wave)
Maximum output	35W
Light fiber	Core diameter 200 $\mu$ m or 400 $\mu$ m
Cooling system	Electronic air cooling by peltier unit
Dimension	270(W) $\times$ 260(D) $\times$ 230(H)
Weight	6.5kg (including cable)

### 4-3. Description

<Front>

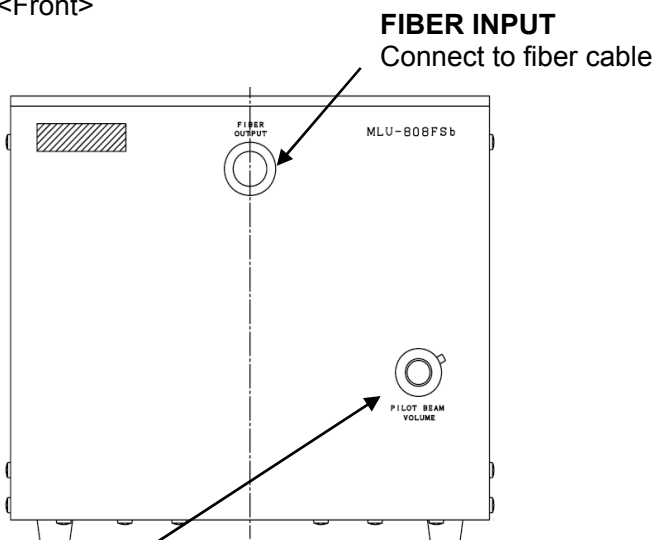

**PILOT BEAM VOLUME**  
to adjust PILOT BEAM  
emitting from fiber.

<Back>

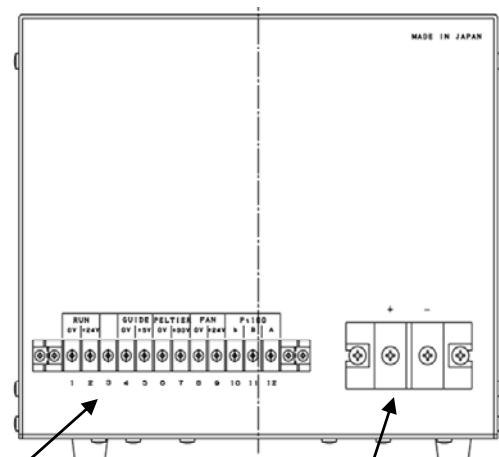

**TERMIANL BLOCK**  
for COOLING CABLE  
Connect to cooling cable.

**TERMINAL BLOCK**  
for OUTPUT CABLE  
Connect to output cable

## 5. Installation and connection

### 5-1. Installation

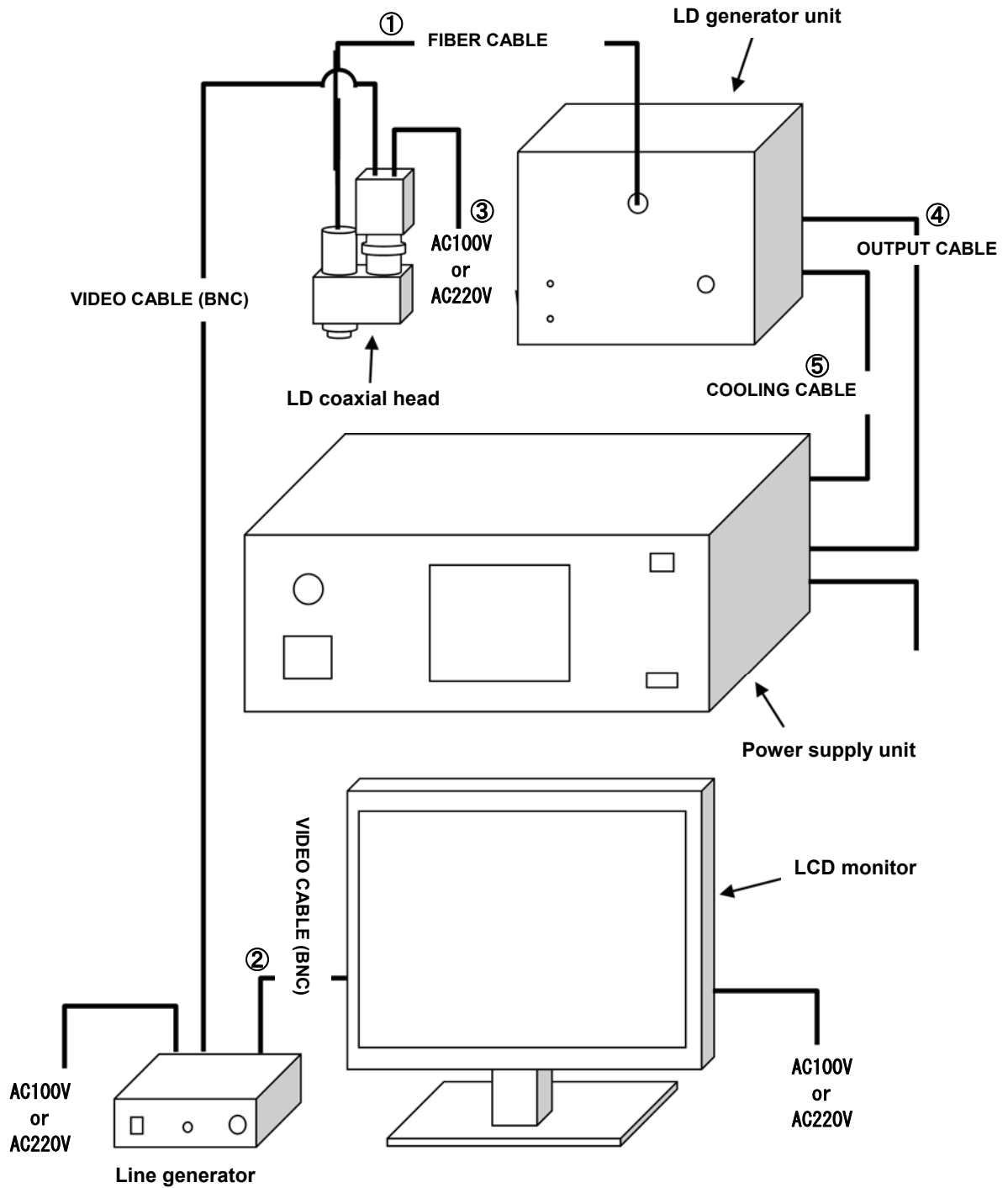



## 5-2. Connection

### 1) FIBER INPUT

Connect FIBER CABLE to FIBER INPUT (SMA connector) of both LD generator unit and LD coaxial unit.



The power supply unit must be turned OFF, when you connect cable.  
Make sure to connect firmly, because the top of the cable emits strong laser light.

### 2) VIDEO OUT

Connect the video cable of Coaxial head to the IN of Line generator.

### 3) DC IN

Connect DC IN cable to AC100V.

### 4) OUTPUT CABLE

Connect OUTPUT CABLE ( + ) ( - ) to TERMINAL BLOCK for OUTPUT CABLE ( + ) ( - ) on the back panel of LD generator unit.



The power supply unit must be turned OFF, when you connect cable.  
Be careful the connection of (+) and (-).  
If the connection is done reversely, LD in the generator unit may be damaged.

### 5) COOLING CABLE

Connect the COOLING CABLE to the terminal block on the back of the LD generator unit as follows.

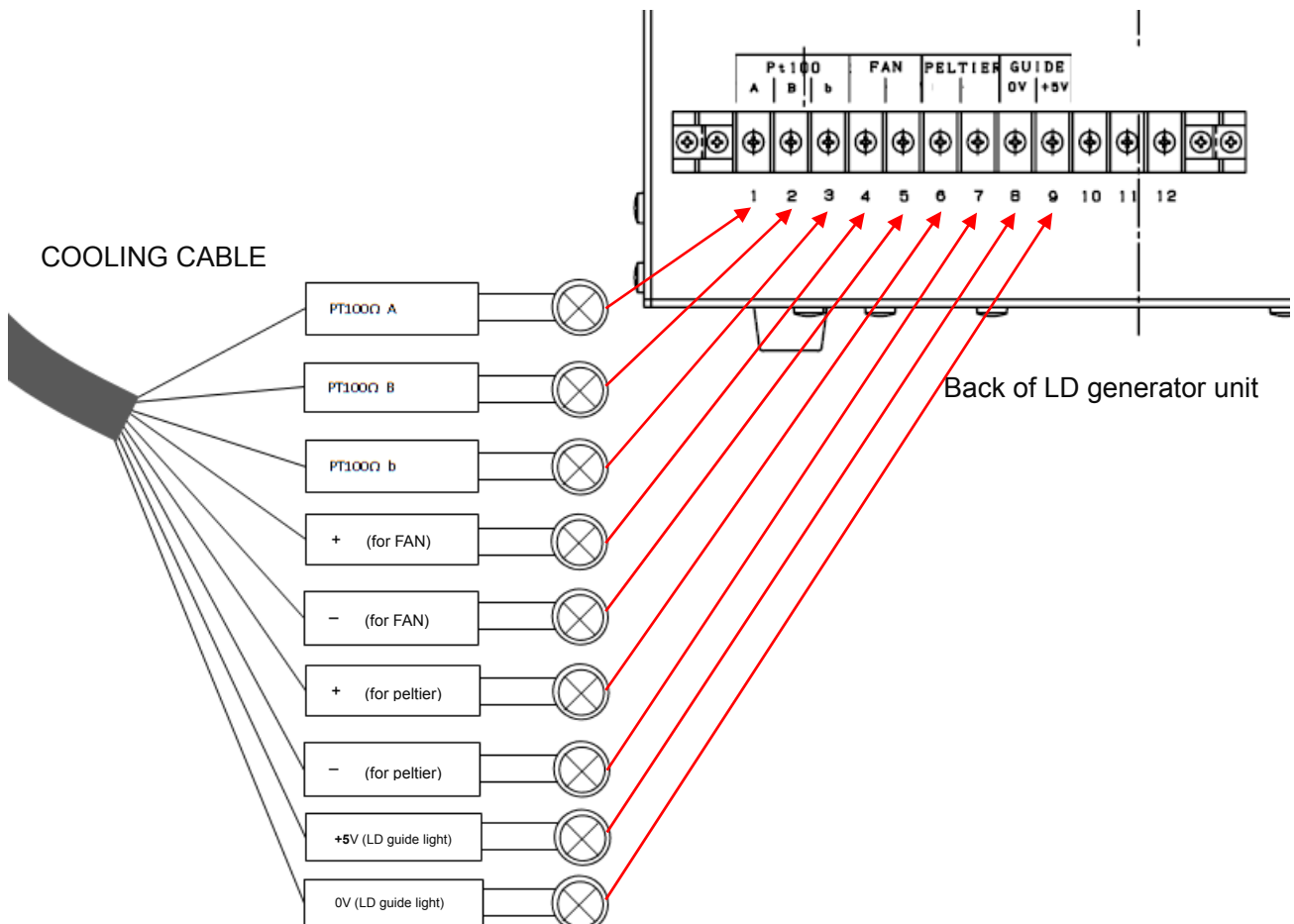

# Power supply unit

## 1. Summary

This power supply is composed of controller's department and LD (laser diode) part and peltier driver part. The operation mode becomes wavy control (DIV) or continuous output (CW) operation. Peltier driver part can be switched from its inside by 30V/8A (24V for FAN) or 18V/8A (12V for FAN)

## 2. Dimension

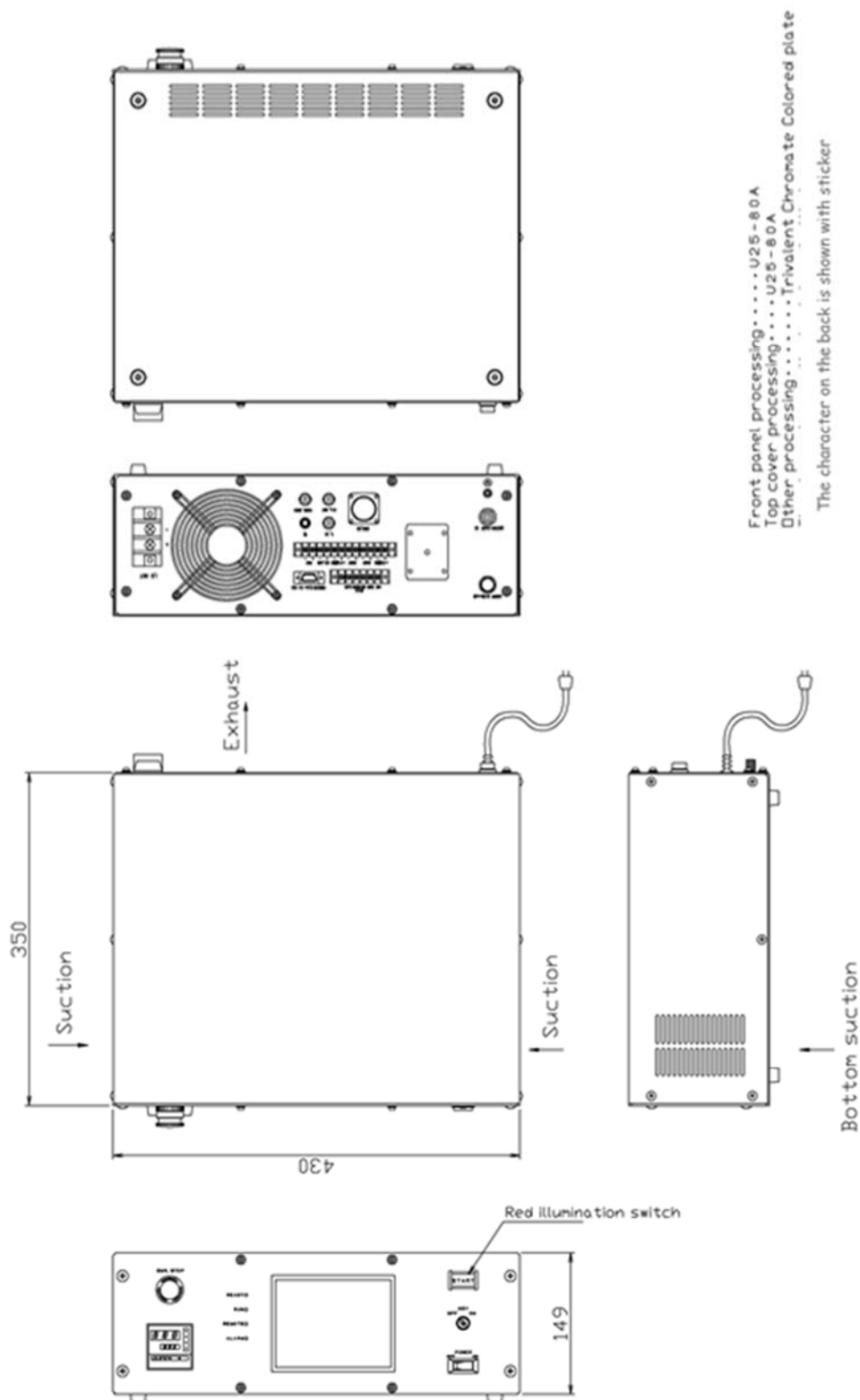

### 3. Specification

- General specification

Input power supply		Single phase AC100V or AC220V $\pm$ 10% 50/60Hz 8A
Operation Condition	Operation temperature	0~40 °C
	Ambient temperature	-20~60 °C
	Relative humidity	20~90%RH (Non condense)
Dimension		430 (W) $\times$ 149(H) $\times$ 350(D) mm
Weight		16kg

- LD driver part

Operation method	Dropper method 1st / 2nd insulation type
Maximum voltage	3V
Maximum current	70A
Maximum power	210W
Current monitor	3.5V / 70A (non-insulation type)
Efficiency	40~60%
Cooling method	Compulsion air cooling method

- Peltier driver part

Peltier output	30V / 8A (max) or 18V / 7A (max) *Peltier output can be set by terminal block in unit. Factory setting 30V / 8A
Peltier element impression voltage / current	30V / 8A (max) or 18V / 7A (max)
Control method	PID pulse width control (heating and cooling control)
Resistance temperature detectors	Pt100 (sensor cable 300mm)
Resolution	0.1 °C
Preset temperature	10.0~40.0 °C
Display	Present temperature display (PV) Set value temperature display(SV)
Warning alarm	Upper / lower limit temperature ALM
Insulation	Insulation between 1st and 2nd
Power supply for FAN	DC24V or DC12V

Temperature controller: TGCSS11 (JUST-made)

After the power supply is turned on, the power for FAN is always turned on.

\*The power supply for FAN can be set by the toggle switch on the unit.

The factory setting is 24V.

## 4. Description

### (1) Front panel

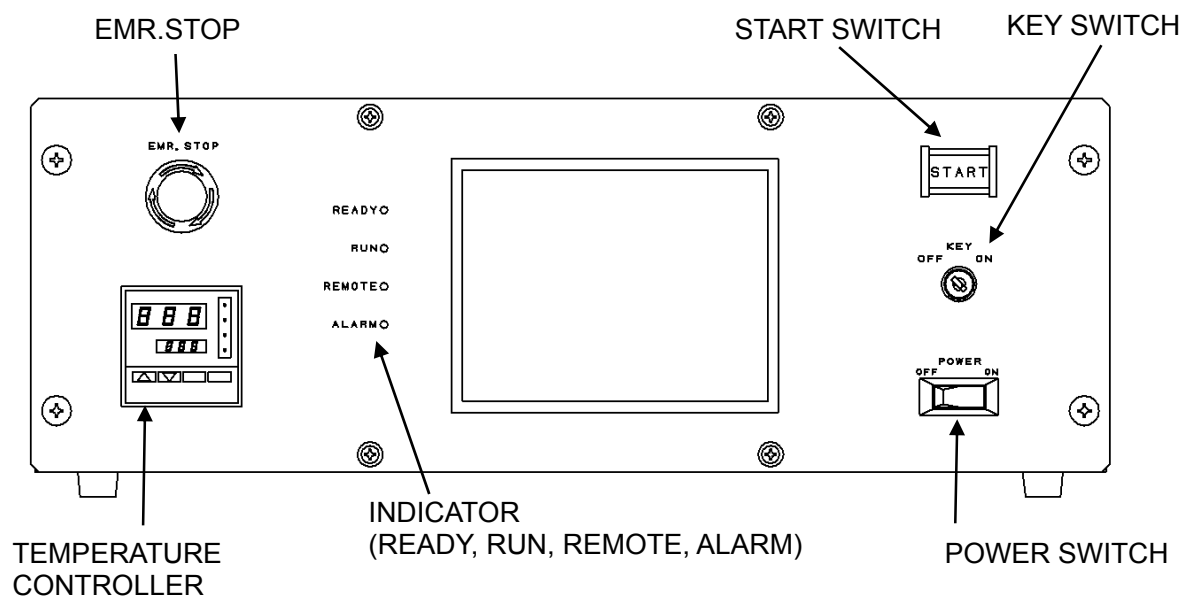

- **EMR.STOP**  
When this button is switched on, the output current is stopped.
- **KEY SWITCH**  
The following KEY SWITCH function can be selected.

#### KEY SWITCH function 1 :

After power on, turn off the KEY SWITCH once and turn on, then the display is shifted to the standby screen.

#### KEY SWITCH function 2:

After power on, the display is shifted to stand by screen and accept the command by RS232C, if KEY SWITCH is turned on skipping the OFF detection of KEY SWITCH.

- **START SWITCH**  
This is the red illuminated mechanical switch.  
The switch lights red during outputting.  
The switch blinks red at alarm.
- **TEMPERATURE CONTROLLER**  
Various setting of temperature control and temperature operation.

## (2) Rear panel

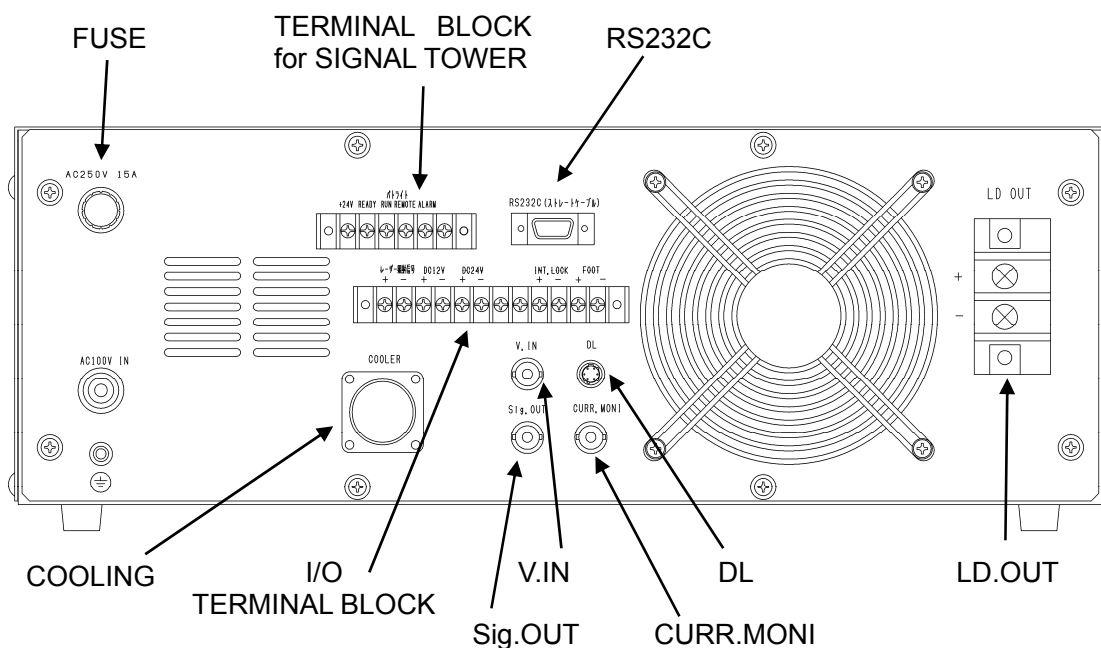

- INT. LOCK (I/O TERMINAL BLOCK)

Interlock signal is released, when between INT. LOCK terminal is closed.  
(Shorten HL, when not in use)

- FOOT (I/O TERMINAL BLOCK)

During EXT mode, the operation can be started, when START SWITCH is pushed.  
It begins to output by external foot switch is closed(ON) in more than 50ms.

\*This EXT.TRIG signal cannot be used as a synchronization signal because of the external start signal. After inputting EXT.TRIG signal, it outputs about 500ms after.

\* We do take NO responsibility on a damage caused during EXT.TRIG mode.

- DC12V (I/O TERMINAL BLOCK)

12V/2.5A (for external microcomputer device ) outputs.

- V.IN (BCN)

It controls external output by inputting external analog signal (0-5V).

- Sig.OUT(BNC)

It outputs after starting and stopping the output signals of TTL level, pulse width 250 $\mu$ s and active High.

- CURR. MONI(BNC)

It is 3.5V/70A

- COOLING

Signal for peltier.

- LD OUT

It is connected to laser diode (LD).

- RS232C (straight cable)

It is connected to RS232C such as PC.

- DL  
Connector for program change.
- TERMINAL BLOCK for SIGNAL TOWER.  
It is connected to the SIGNAL TOWER.

## 5. Connection

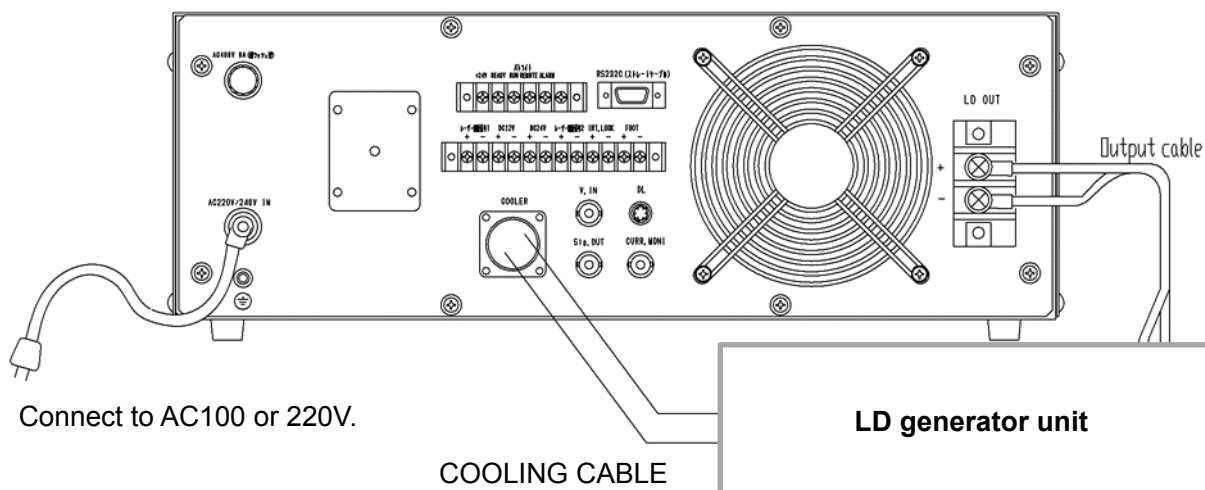

- 1.) Power supply input  
Connect the power cable on the back panel to AC100V or AC220V  
⚠ Make sure to connect PE terminal at this time.
- 2.) OUTPUT CABLE  
Connect OUTPUT CABLE to LD OUT terminal (+)(-) on the back of the power supply unit.
- 3.) COOLING CABLE  
Connect COOLING CABLE to COOLING connector on the back of the power supply unit.

## 6. Notice

---

- 1.) For hazard prevention, please make sure to turn off the main switch and wait for more than 10 minutes, when you exchange such as laser diode.
- 2.) The fuse must be time lag fusion type.
- 3.) Please be sure to ground a frame grand terminal. If it is not properly grounded, electrical shock or damage to you may occur
- 4.) The set parameter is backed up with battery and is valid for about 10 years. When battery replacement is needed, please send back power supply to Apollo Seiko or our distributors. We will replace battery. In this case, the parameter is initialized.
- 5.) It may be unable to follow, when the current is changed from less than 2A into more than 20A on the DIV mode current setting.

## 7. Basic operation

---

### 7-1. Remote and Local mode

[REMOTE] It is controlled by RS232C (serial communication).

[LOCAL] It is controlled by the touch key (LCD).

REMOTE LED lights on REMOTE mode.

\*When power on, it is mode set by back key.

### 7-2. Operation mode

[SINGLE] 1 shot operates by set electric power value / current value and pulse width.

[REPEAT] It repeatedly outputs the waveform registered continuously.

It is stopped by START SWITCH (at LOCAL) or Z command (at REMOTE).

[COUNT] It repeatedly outputs registered wave form only at the set count value and it stops.

It is possible to be stopped by START SWITCH (at LOCAL) or Z command (at REMOTE) during operation.

\*When power on, it's SINGLE mode.

### 7-3. Control mode

[CW] It operates continuous output only during automatic stop time set by electric power value or current value.

When the stop time is '0', it is stopped by START SWITCH (at LOVAL) or Z command (at LOCAL).

[DIV] It changes electric power value or current value in every 100mS.

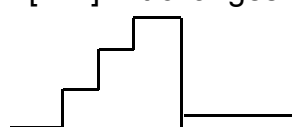

100mS / Step Maximum 100 steps maximum pulse width  
It can be set No.1~16 Waveform at 10S max setting.

\*When power on, it's DIV mode.

## 7-4. Trigger mode

[INT] It operates by the parameter setting with touch key.

[EXT] It operates by external input.

[INT E] It controls output current by analog input (0-5V) from external output.

[EXT E] It operates by external FOOT SWITCH and controls output current by analog input (0-5V) from external input.

\*When power on, it's SINGLE mode.

## 7-5. Output setting

Please set Power or Current by 'Output mode' on the back screen.

Current ... can be set by current value.

Power ... can be set electric power value.

\*At Power setting, electric power value for current value is set by POWER MAP EDIT.

(Maximum 500 points)

## 8. Operating procedure

---

## 8-1. Power on

1.) Turn on POWER SWITCH on the front.

2.) By power on, 'WAIT A MINUTE' is displayed on LCD and the internal data is initialized.

3.) After initializing time, 'KEY SWITCH ON' is displayed on LCD (when it's already on, "OFF" is displayed), turn on KEY SWITCH.

## 8-2. Power off

1.) Turn off KEY SWITCH.

2.) Turn off POWER SWITCH.

## 8-3. Setting change

Setting change is done by touch key of main screen.

Only [RMT.] key can be accepted at REMOTE mode.

[RMT.] key: The operation mode can be changed. (REMOTE / LOCAL)

[PARA] key: The parameter for power supply controller can be set. (INT/EXT)

[MODE.] key: The operation mode and trigger mode can be changed.

[FUN.] key: Shot counter can be reset.

It is shifted to shot counter reset screen, when push [FUN.] key on main screen. After [PUSH] key is pushed once, [OK?] on the same key

starts

blinking.

When the key is pushed again, it is reset to 0 count.

It is cancelled by pushing other keys.

[WAV] key: It calls registered wave form (No.1~16).

[START] switch: It operates output start and stop.



## 8-4. Parameter

## Electric power setting

Parameter	Setting range	Setting resolution
DIV electric power value	0.00~99.99W	0.01W
CW electric power value	0.00~99.99W	0.01W

## Current setting

Parameter	Setting range	Setting resolution
DIV electric power value	0.2~70.0A	0.1A
CW electric power value	0.2~70.0A	0.1A

## Common setting

Number of steps	1~100STEP	1STEP
Control mode	DIV / CW	...
Automatic stop mode	0.0~3600.0s	0.1s
COUNT value	1~99999CT	1CT

Electric power value ... It outputs with setting electric power value.

The electric power value on the main screen shows maximum value. The setting range depends on the registered data.

e.g) When the maximum electric power value 50.00W is registered,

it becomes up to 50.00W

Current value... It outputs with setting step current value.

The current value on the main screen shows maximum current.

Number of step... 100ms pulse width per 1 step.

## 8-5. Step electric power setting (details)

At the parameter setting screen, set the pulse width which you want to be outputted with pushing [PUSH] key of STEP.



[◀] [▶] key: Select step changing electric power value by this key.

[▲] [▼] key: By [▲] [▼] key, change electric power value of selected step.

Numeric key: Change electric power value of selected step by the numeric key.

[FLAT] key: The electric power value of previous step is copied and is proceeded to next step.

[MIN] [MOUT] key: When [MIN] key is pushed, entered electric power value is saved in the storage memory (1~16).  
 When [MOUT] key is pushed, the storage memory (1~16) is called.  
 When you push the key, Wave form number (1~16) is displayed.  
 After select the save or call memory, push [PUSH] key.

[MK→ST] key: It can be set waveform gradually.  
 Select starting point with [◀] [▶] key, and set electric power value.  
 Also push 'MK' of [MK→ST] key left side.  
 When you push 'SK' of [MK→ST] key right side, changed waveform is set in every step gradually.

[EXIT] key: Back to waveform entering screen.

## 8-6. Operation restriction

## Power restriction

- On DIV mode: LD voltage value (V)×Current mean value(A) >Power upper value(W)
- On CW mode: LD voltage value(V)×Current value(A) >Power upper value(W)

\*The operation stops as over power error, when the power exceeds upper value.

## 8-7. Parameter setting by back key



**Warning : When LD voltage value exceeds 40A, it may occur malfunction.**

## 8-7-1. Parameter setting

When power on, as pushing on the right upper corner on the display, parameter setting screen is displayed after a few second. The following parameter setting can be changed. By changing parameter value, LD load damage can be prevented.

Parameter	Setting range	Factory setting
Power upper limit value (POWER LIMIT)	21.00~210.00W	210.00W
DIV current upper limit value (PLS CURR LIMIT)	0.2~70.0A	40.0A
CW current upper limit value (CW CURR LIMIT)	0.2~70.0A	40.0A
Pulse width upper limit (PULSE LIMIT)	100m~10000ms	10000mS
Operation mode when power on (OP MODE)	LOCAL / REMOTE	LOCAL
KEY SWITCH operation mode when power on (KEY SWITCH)	SKIP / NORMAL	NORMAL
Total counter reset (T.COUNTER RESET)	Reset of total counter	_____
(ALL DATA RESET)	Reset of all data	_____
Temperature control (TEMP.CONTOROL)	ON / OFF	ON
Conversion data registration of electric power value (Power Map Edit)	0.2A~70.0A 0W~100W	0.2A 0W
(Output Mode)	Power / Current	Current

- Operation mode when power on  
REMOTE LED lights at REMOTE mode.  
At REMOTE mode, main screen is displayed and starts communication control after power on.
- KEY SWITCH  
It becomes KEY SWITCH function 1 at NORMAL and becomes function 2 at SKIP.
- Total counter reset and all data reset  
When [RES.] key is pushed once, this key starts blinking.  
And it is pressed again, it is reset. The other key is pressed, it is cancelled.
- Temperature control  
When power on, the alarm detection is enabled.

## 8-7-2. POWER MAP EDIT

## 1.) Conversion data registration at electric power setting (Power Map Edit)

Electric power value registrable minimum resolution 0.1A

Registrable power minimum resolution 0.01W

Registrable power maximum value 99.99W

Registrable maximum point 500points

· The conversion data is a valid data, when Out Put Mode on the back screen is at 'Power'.  
The current value between outputs by the electric power value set at main screen is calculated according to the registered current and electric power value here in.

※CAUTION※ The relation of registered current and power should rise to the right.  
When the power decreases as the current increases (Figure 1),  
A and B point are shown to be the same data (Figure 2)

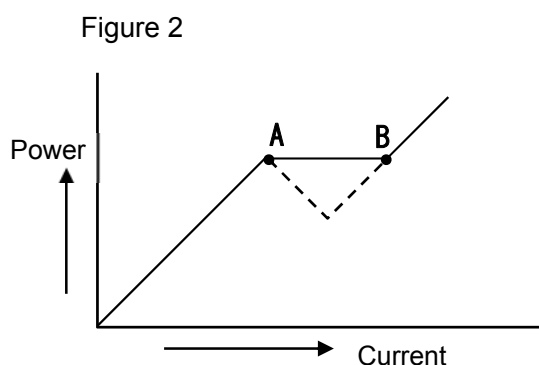
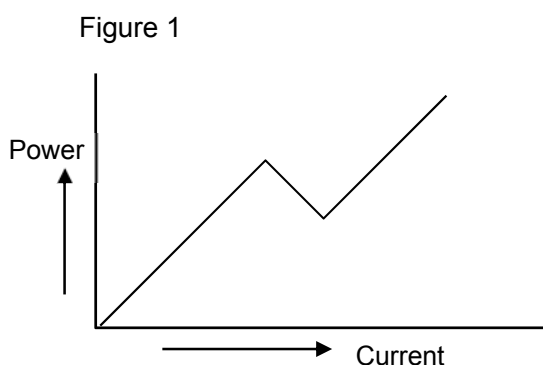

The number of registered maximum points is any 1~500 points.

The directive power which exceeds registered power cannot be entered.

The area without registered power is calculated output current by linear interpolation of before and after point.

Changing the registered power is the change of the power to setting current value.

## 2.) Registration procedure

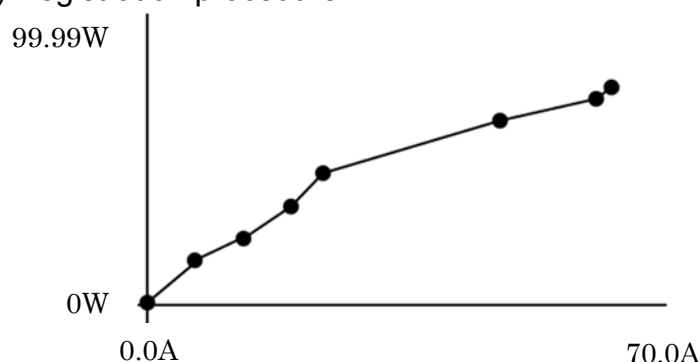

1. Press 'POWER MAP EDIT' on the back screen. When EDIT key is pressed at Edit screen, a numeric key is displayed. Enter point of the current (A) and power (W). Then the output current value is calculated according to the translation table.
2. Press [Exit] key and [OK] key for data saving.
3. Press [Reset] key and [OK] key to delete data.

Note 1) Increase current value as power increases.

Note 2) The current value is max 500 points in every 0.1A.

## 8-8. Switching peltier output voltage and FAN power supply

 Please make sure to unplug the power cable, when switching is done.

- 1.) Open the cover of main body.
- 2.) Switch terminal block for Peltier output voltage.  
Switch toggle for FAN power supply.  
(refer to the pictures below.)
- 3.) Close the cover.

### • Setting peltier voltage 18V



Short-circuit +18V and C on the terminal.

### • Setting peltier voltage 30V

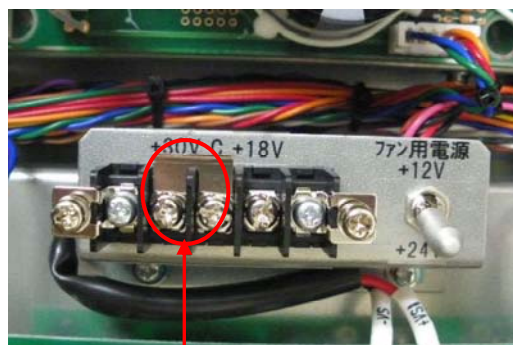

Short-circuit +30V and C on the terminal

### • Setting FAN power supply +12V

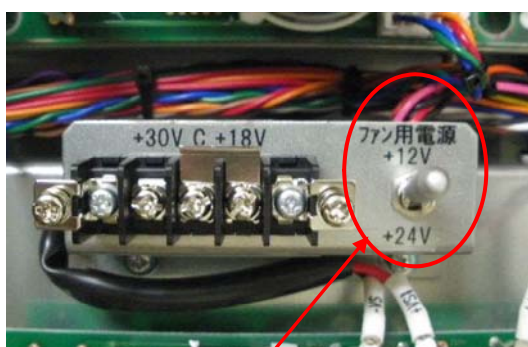

Put up the toggle switch to +12V side.

### • Setting FAN power supply +24V

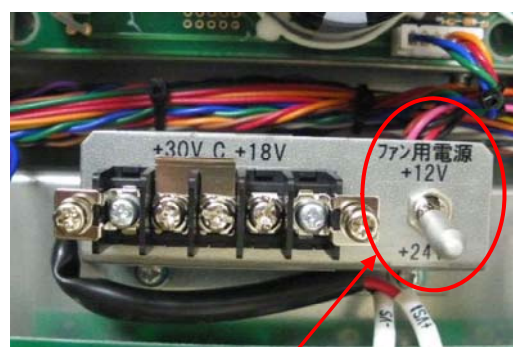

Put down the toggle switch to +24V side.

## 9. Remote mode

This mode is controlled by RS232C.

### 9-1. Communication parameter

Baud rate	9600bps
Data length	8 bit
Stop bit	1 bit
Parity	none
Delimiter	[CR] [LF]

The connection cable is straight (normal) type.

※Note※

When the command is not sent properly or is sent continuously, the update of temperature display may be delayed.

### RS232C

Pin No.	Signal name
1	-----
2	TXD
3	RXD
4	(DSR)
5	SG
6	(DTR)
7	CTS
8	RTS
9	-----

Connector : 17JE-23090-02(D2A) (DDK-made)  
 Applicable connector: 17JE-13090-02(D8A)  
 (DDK-made) equivalence

### 9-2. Command

#### (1) 'R' command

Waveform No. is switched.

e.g) R : 16 [CR] [LF]

Delimiter

1~16: Wave No.

#### (2) 'A' command

DIV current value or electric power value is set.

e.g) A : 100, 500 [CR] [LF]

Delimiter

2~700: Current value  $\times 10$   
 0~9999: Electric power value  $\times 100$

1~100: Step No.

(3) 'S' command  
The number of steps is set.

e.g) S : 100 [CR] [LF]

1~100: Step No.

Delimiter

(4) 'T' command  
Trigger mode is switched.

e.g) T : I [CR] [LF]

I:INT mode  
E:EXT mode (external foot switch operation)  
A:INT E mode (external analog input control)  
F:EXIT E mode (external foot switch operation,  
external analog input control)

Delimiter

(5) 'Y' command  
Operation is started.

e.g) Y : [CR] [LF]

Delimiter

(6) 'Z' command  
Operation is stopped.

e.g) Z : [CR] [LF]

Delimiter

(7) 'Q:1' command  
 Status 1 is demanded.

e.g) Q : 1 [CR] [LF]  
 \_\_\_\_\_ Delimiter

ACK e.g)

D, 50.0,50.0, ... , 50.0,100,5000,99999,99.0,16,S, I [CR] [LF]  
 ① ② ③ ④ ⑤ ⑥ ⑦ ⑧ ⑨ ⑩⑪ ⑫ \_\_\_\_\_ Delimiter

- ① Control mode D:DIV C:CW
- ② Current value (Maximum value at DIV mode)
- ③ The 1st step current value
- ④ The 2nd ~ 99th step current value ( is separated by commas)
- ⑤ The 100th step current value
- ⑥ Number of steps
- ⑦ Pulse width
- ⑧ Counter value
- ⑨ Time
- ⑩ Wave No.
- ⑪ Operation mode S:SINGLE R:REPEAT C:COUNT
- ⑫ Trigger mode I:INT  
 E:EXT (external foot switch operation)  
 A:INT E mode (external analog control)  
 F:EXT E mode (external foot switch operation, external analog input control)

(8) 'Q:2' command  
 Status 2 is demanded.

e.g) Q:2 [CR] [LF]  
 \_\_\_\_\_ Delimiter

ACK E(.)

R, K [CR] [LF]  
 \_\_\_\_\_ Delimiter

K: Normal

E: Under alarm generating

R: Under operating

S: Under suspension  
 (laser operation is possible)

B: Under suspension  
 (laser operation is impossible,  
 waiting for KEY ON)



## (9) 'E' command

The running state of previous command is demanded.

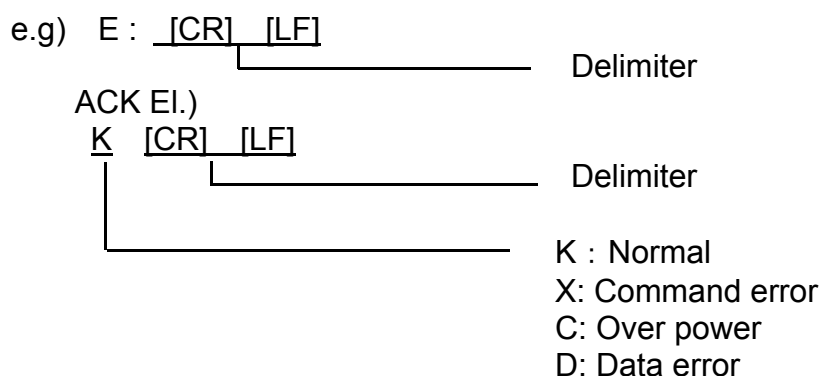

## (10) 'G' command

The present data is registered to specified waveform number.

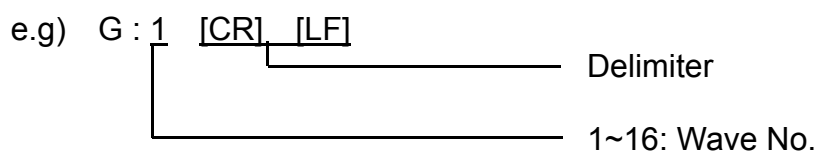

## (11) 'B' command

CW current value or electric power value is set.

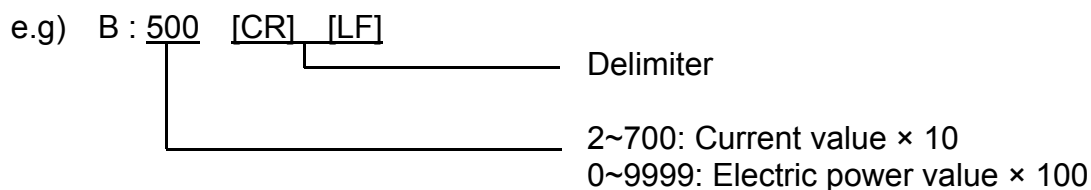

## (12) 'J' command

Automatic stop time of CW is set.

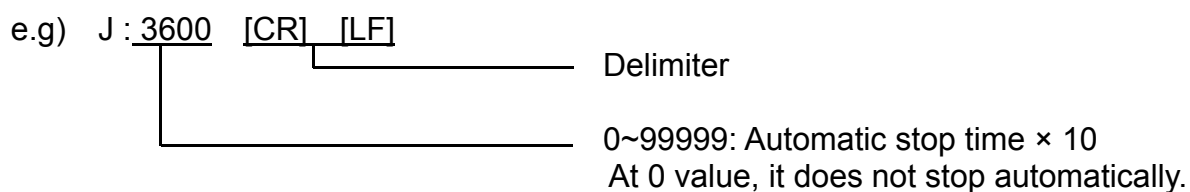

\*Start-up is by Y command, Stop is by automatic stop or Z command.

(13) 'K' command

It operates only specified repeat number

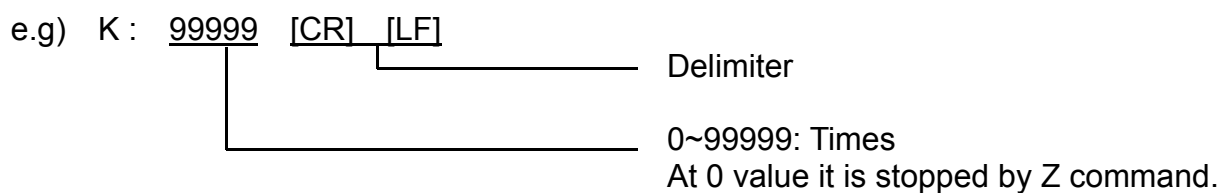

(14) 'M' command

Control mode is switched.

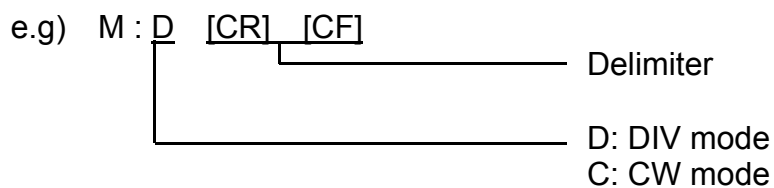

(15) 'H' command

Operation mode is switched.



(16) 'I' command

Map is made out.

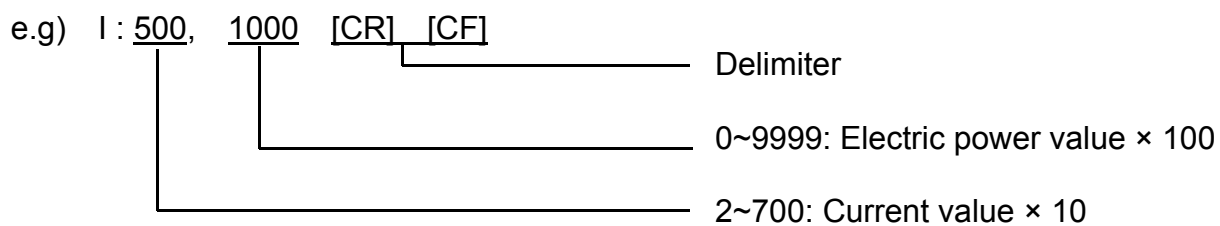

## (17) 'P' command

Map data is read out.

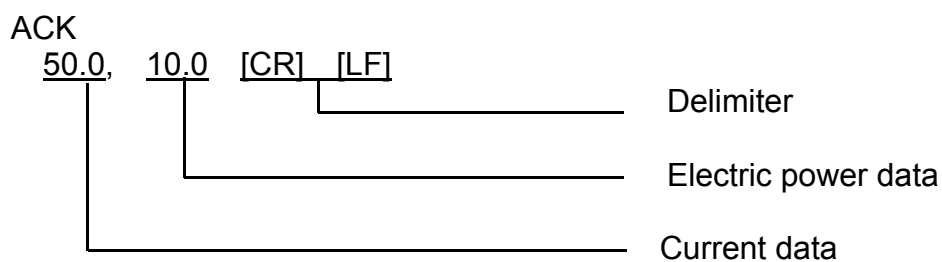
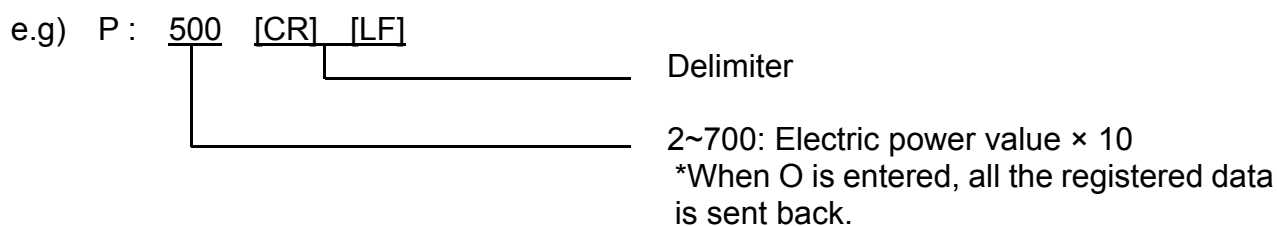

## (18) 'O' command

Map data is saved.



Note 1.) The command data of A,B,C, D, Q: 1 varies by electric power or current setting set on the back screen.

Note 2.) When Map data exceeds 500 points, data is not saved even if O command is executed. When E command is executed, Map data is not saved, however the command form is correct, 'K' of ACK is sent back. So please be careful.

Note 3.) Make sure to receive the send back data in the command with ACK.

## 10. Function

### 10-1. INT.LOCK (I/O TERMINAL BLOCK)

When between INT.LOCK terminal is closed, inter lock signal is released.

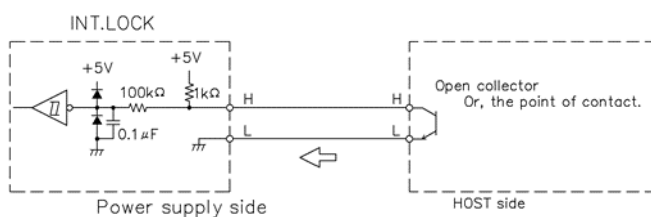

### 10-2. Sig.OUT (BNC)

The signal of TTL level, pulse width 250μS and active High outputs after start and stop.

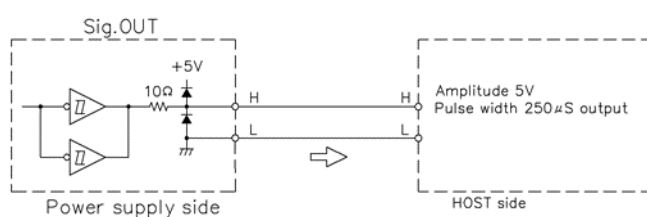

### 10-3. CURR.MONI (BNC)

It is 3.5V / 70A

### 10-4. EMR.STOP

It stops, when EMR.STOP button is pushed.

### 10-5. FOOT (I/O terminal block)

At EXT mode, after press START key, it become possible to operate. It starts outputting, when the external FOOT SWITCH is closed (ON) in more than 50ms.

When stopping, FOOT SWITCH is closed (ON) again.

This FOOT signal cannot be used as a synchronized signal because it is external start signal.

Also after inputting EXT.TRIG signal, it is outputted from after about 500mS.

\*We do take NO responsibility on a damage at EXT.TRIG mode.

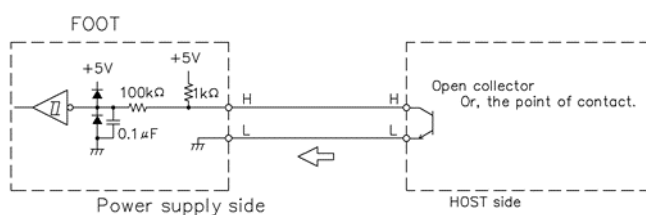

10-6. Power output (I/O TERMINAL BLOCK)  
 12V / 2.5A (for external microcomputer) is outputted.

10-7. KEY SWITCH  
 The following KEY SWITCH function can be selected.

KEY SWITCH function 1 :  
 After power on, turn off the KEY SWITCH once and turn on, then the display is shifted to the standby screen.

KEY SWITCH function 2:  
 After power on, the display is shifted to stand by screen and accept the command by RS232C, if KEY SWITCH is turned on skipping the OFF detection of KEY SWITCH.

10-8. START SWITCH  
 It is the red illuminated mechanical switch.  
 The switch lights red during outputting.  
 The switch blinks red at alarm.

10-9. Laser irradiation signal (I/O TERMINAL BLOCK)  
 Laser irradiation signal became ON while output current is outputting.  
 It outputs with open collector. External power supply is used under 28V / 20mA.

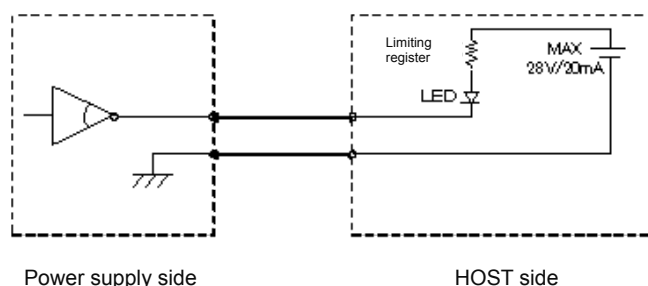

10-10. V.IN (BNC)  
 By inputting analog signal (0-5V), output current which is calculated with the formula below is controlled.

$$k = E_d / 5$$

$$I_d = I_o \times k$$

$I_d$  = Output current  
 $I_o$  = Set current value  
 $E_d$  = External analog signal (0-5V)

When external analog signal 5V is inputted, it is outputted with set current value.  
 Output current is updated in more than 6mS

It enables at INT E mode.

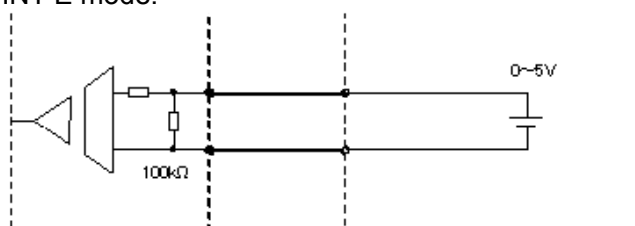

## 10-11. SIGNAL TOWER signal (I/O TERMINAL BLOCK)

It outputs with open collector.

The power supply for signal tower is used under DC24V / 0.5A.

- READY            · · · READY signal is turned ON, when the output is enabled.
- RUN             · · · RUN signal is turned ON, during laser irradiation.
- REMOTE        · · · REMOTE signal is turned ON at REMOTE.
- ALARM          · · · ALARM signal is turned ON at ALARM.

## 10-12. Power supply output (I/O TERMINAL BLOCK)

24V / 1A (for external power supply) is outputted.

## 11. Pin Assignment

---

## 11-1. COOLING

Pin No.	Signal name
1	PT100Ω A
2	PT100Ω B
3	PT100Ω b
4    *2	+12V / +24V (for FAN)
5	C12V / C24 (for FAN)
6    *1	+18V / +30V (for peltier)
7	COM (for peltier)
8	+5V (for LD guide light)
9	0V (for LD guide light)
10	-----

\*1 Peltier output can be set at the terminal block on the back panel.

The factory setting is 30V / 8A.

\*2 FAN power supply can be set with toggle switch on the back panel.

The factory setting is 24V.

Connector: NJC-2410-RF (Nanaboshi-made)

Applicable connector: NJC-2410-PM (Nanaboshi-made)

\*COOLING connector depends on its type.

- COOLING power supply
  - Peltier output 30V / 8A or 18V/7A
  - FAN output 24V / 0.5A or 12V/0.11A
  - LD guide light power supply 5V / 0.12A (for LD guide light)

## 11-2. I/O Terminal block

Pin No.	Signal name
—	DC24V+ (for external power supply)
—	DC24V- (for external power supply)
—	—————
—	—————
—	INT.LOCK+
—	INT.LOCK-
—	FOOT+
—	FOOT-
—	Lase irradiation signal +
—	Laser irradiation signal -
—	DC12V + ( for external microcomputer)
—	DC12V – (for external microcomputer)

TERMINAL BLOCK: ML-40-S2AXF-12P(M3) (Sato parts-made)

## 11-3. SIGNAL TOWER

Pin No.	Signal name
—	+24V
—	READY
—	RUN
—	REMOTE
—	ALARM
—	—————

TERMINAL BLOVK: ML-40-S2AXF-6P(M3) (Sato parts-made)

## 11-4. LD OUT

Pin No.	Signal name
—	+
—	-

TERMINAL BLOCK: F2056E-2P-CT (Fujicon –made)

## 11-5. Sig OUT

Pin No.	Signal name
—	+
—	-

Connector: (BNC) BNC-31-10L (Toyo connector-made)

## 11-6. CURR.MONI

Pin No.	Signal name
—	+
—	-

Connector: (BNC) BNC-31-10L (Toyo connector-made)

## 11-7. V.IN

Pin No.	Signal name
—	+
—	-

Connector: (BNC) BNC-31-10L (Toyo connector-made)

## 12. Temperature controller

---

### 12-1. Auto tuning

**\*Before operation, please auto-tune in order to stabilize the control operation.**

Please follow the procedure below after LD to be used is mounted.

#### 1.) Set the SV display to desirable operating temperature.

Press MODE key.



Set SV display with ▲ key or ▼ key.



Press MODE key.

#### 2.) Execution of Auto tuning

Press ▲ key and +MODE key for PV display.



SV displays “ - - - ”.



After pressing ▲ key, SV displays ‘A’.



After pressing MODE key, it becomes PV/SV display mode.  
AT display blinks, then auto tuning starts.



After 5~10 minutes (depending on heating state and set temperature),  
auto tuning finishes (AT display blinks) and it becomes normal control mode.

**Please make sure to auto tune whenever LD head is replaced or operating environment is changed.**

\*More details for temperature controller, please refer to its instruction manual.



## 12-2 Factory setting

Settings	Setting value	Set item	Setting value
Control output OFF function	Release	Sensor selection (L <sub>En</sub> )	Pt 100Ω (P <sub>T.C</sub> )
Main set value (L <sub>1</sub> )	25°C	PV filter constant setting (FI <sub>1</sub> )	0.0 sec
Auto tuning (A <sub>1</sub> )	Release (---)	Output upper limit setting (OH)	100%
Proportional band setting (P)	10°C	Output lower limit setting (OL)	5%
Integration time setting (I)	200 sec	Alarm A1 operation selection (AL1)	Upper and lower limit range alarm operation (L <sub>Id</sub> )
Derivative time setting (D)	50 sec	Alarm A2 operation selection (AL2)	No operation
Proportional cycle setting (c)	3 sec	Alarm A1 operation excitation /non-excitation selection (A1L)	Excitation (non)
Temperature alarm A1 operation setting (A1)	10°C	Alarm A1 operation excitation /non-excitation selection (A2L)	Excitation (non)
Temperature alarm A2 operation setting (A1)	0°C	Alarm A1 operation gap setting (A1H)	0.5 °C
Setting value lock designation (Loc)	Release (---)	Alarm A2 operation gap setting (A2H)	1.0 °C
Main setting value upper limit (L <sub>H</sub> )	40°C	Alarm A1 operation delay timer setting (A1d)	0 sec
Main setting value lower limit (L <sub>L</sub> )	10°C	Alarm A1 operation delay timer setting (A2d)	0 sec
Sensor correction setting (L <sub>0</sub> )	0°C	Output positive / reverse switching (cn <sub>1</sub> )	Positive (cooling) Operation (co)
		AT bias setting (A <sub>1</sub> b)	2.0 °C

 Temperature A1 operation is set in Upper and lower limit range alarm operation as temperature control fault.

If setting temperature (SV display) 25°C, Upper and lower limit range alarm 9.5°C and Alarm A1 operation gap 0.5°C are set, it alarms when the alarm signal point is opened and LD power output is stopped in more than 35.0°C or under 15.0°C.

 Temperature alarm A2 operation alarms when peltier driver output and LD power output are stopped at burn-out alarm (temperature detector PT100Ω is disconnected or shortened). Do not change Temperature alarm A2 value of factory setting.

## 13. Parameter of factory setting

Back screen		Main screen	
POWER LIMIT	210.00 W	WAVEFORM MODE	DIV
PLS CURR LIMIT	70.0 A	PLS CURR. (MAX)	0.2A
CW CURR LIMIT	70.0 A	CW CURR.	0.2A
PULSE LIMIT	10000mS	STEP	1
OP MODE	LOCAL	COUNT	1CT
KEY SWITCH	NORMAL	TIMER	0.0S
T. COUNTER	0e0CT	SHOT MODE	SINGLE
TEMP. CONTROL	ON	TRIGGER MODE	INT
Output Mode	Current		

## 14. Alarm display

NO	Display	Description	Reason	Solution
1	EMERGENCY!	Emergency stop	EMR.STOP button is pressed.	After turning the button to the direction of arrow, turn KEY SWITCH off/on.
2	KEY SWITCH OFF!	Key switch	KEY SWITCH is turned off.	Turn KEY SWITCH on.
3	TEMP ERROR 1	Heat sink temperature fault	The temperature of heat sink inside power became more than 75°C	After heat sink temperature becomes under 75°C, turn KEY SWITCH off/on.
4	TEMP ERROR 2	Temperature control fault	Peltier temperature exceeds upper and lower limit range.	When peltier temperature returns in limit range, alarm will be released.
5	POWER ERROR	Internal power fault	Failure of internal power	Contact to Apollo seiko or our distributors.
6	INTER LOCK	Inter lock	Inter lock input is opened.	Close inter lock and turn KEY SWITCH off/on.
7	CURRENT OVER	Overcurrent fault	Current exceeds 110% maximum current	Contact to Apollo seiko or our distributors.
8	OVER POWER	Over power	Power exceeds maximum electric power.	Turn KEY SWITCH off/on.

Note 1.) When the above alarm occurs, LD power part is stopped, LED of STAR SWITCH blinks red, big message is displayed on LCD and alarm is sounded continuously. At temperature control anomaly, the buzzer is stopped, when the temperature returns in limited range.

Note 2.) At overcurrent anomaly, POWER ERROR or CURRENT OVER is displayed.

Note 3.) At INTER LOCK error, current command is turns OFF by inter lock hard circuit.

Note 4.) The alarms excepting for TEMP ERROR2 are self-held. CURRENT OVER alarm cannot be released by KEY SWITCH, re-turn on the power.

## 15. Troubleshooting

Please confirm the following list.

Trouble	Failure reason	Recommend solution
Power cannot be supplied.	Power cable is disconnected.	Check the power cable.
	Fuse is blown.	Check the fuse and its capacity.
INTER LOCK alarm occurs.	INTER LOCK is opened.	Shorten INTER LOCK.
TEMP ERROR1 alarm occurs.	Operating temperature exceeds 40°C.	Operate under 40°C.
	Suction port is blocked.	Leave space more than 5cm between suction port and neighbors.
	Rotation of the fan is slow,	Replace to a new fan.
	Suction port is covered with dust.	Clean up suction port and remove dust.
TEMP ERROR2 alarm occurs.	COOLING cable is disconnected.	Check COOLING connection.
	Peltier temperature exceeds upper and lower limit setting range.	Use within setting range.
Output current does not output.	Output cable from LD OUT is disconnected. Polarity is not proper.	Check LD OUT connection.
	CURR.MONI (BNC) is not outputted.	Check CURR.MONI output. (3.5V / 70A)
	Operation mode setting is not proper.	Check the operation mode of DIV / CW mode.

## 16. Maintenance

---

If the cooling fan is clogged, internal temperature may rise and occurs malfunction.  
Please clean the fan regularly about once every several months or half year.

When the rotation speed of cooling fan was significantly reduced, please contact Apollo Seiko or our distributors.

### Caution

- The battery and fan which were expired affect the unit.
- The battery life when it was used 20°C is about 10years.  
If ambient temperature rises, the battery life is shortened.  
It depends on operating environment, the rotation speed will be 80% in about 5~8 years.
- If the environment is dusty or oily, it might stop in 2~3 years,

\*We do take NO responsibility on damage or loss caused by malfunction.

## 17. Protection function

---

### 1.) LD protection

When power off, short-circuit the output terminal (LD OUT)  
(When power on, it is open.)

### 2.) Current limit

It is limited by hard circuit so that output current does not flow over 70.1A.

### 3.) Heat sink temperature fault

The operation of LD power part is stopped and it alarms,  
when the temperature of the internal power heat sink exceeds over 75°C.

### 4.) Temperature control fault

The operation of LD power part is stopped and it alarms,  
when peltier temperature exceeds the upper and lower limit range.

### 5.) Inter lock

The operation of LD power part is stopped and it alarms, when inputting the inter lock is opened.

### 6.) Overpower

It alarms, when it is set to more than the maximum power.

## 18. Block diagram

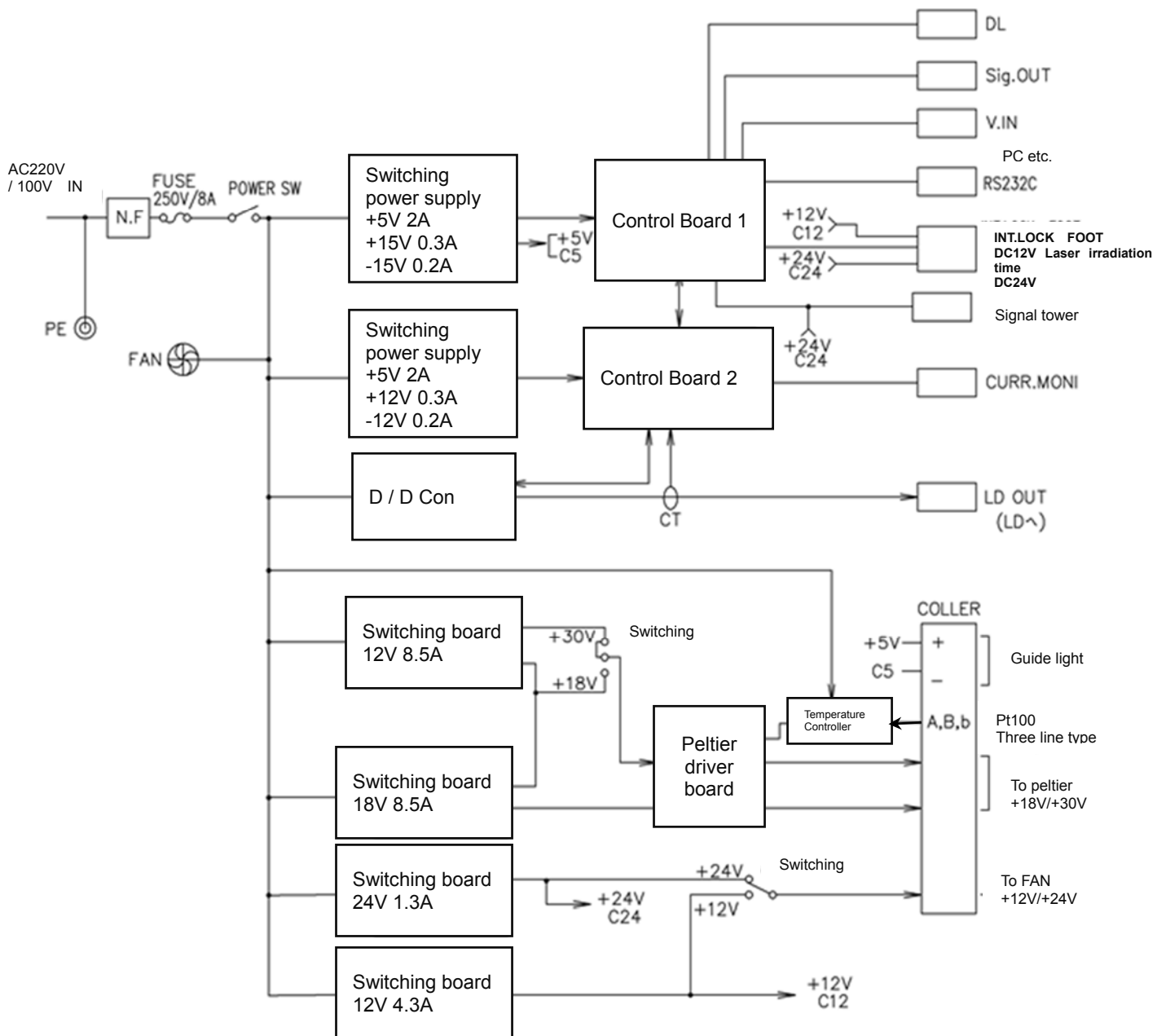

**Apollo Seiko Ltd.**  
2271-7, Jinba, Gotenba-shi  
Shizuoka, Japan 〒412-0047

**Tel: +81(0)550 - 88 - 2828**  
**Fax: +81(0)550 - 88 - 2830**  
**E-mail: [sales@apolloseiko.co.jp](mailto:sales@apolloseiko.co.jp)**  
**URL: <http://www.apolloseiko.co.jp>**